



MAINTENANCE MANUAL

MANUEL DE RÉPARATION - REPARATIEVOORSCHRIFTEN

for NSU Dealers - à l'usage des représentants NSU - voor NSU dealers

Technical Data - List of Special Tools - Flat Rate Repair Times

Caractéristiques - Outillage spécial - Barème des réparations

Technische aanwijzingen - Lijst van speciale gereedschappen - Richtijden der werkzaamheden



Prima

AMSTERDAM

CLUB DEUTSCHLAND E.V.

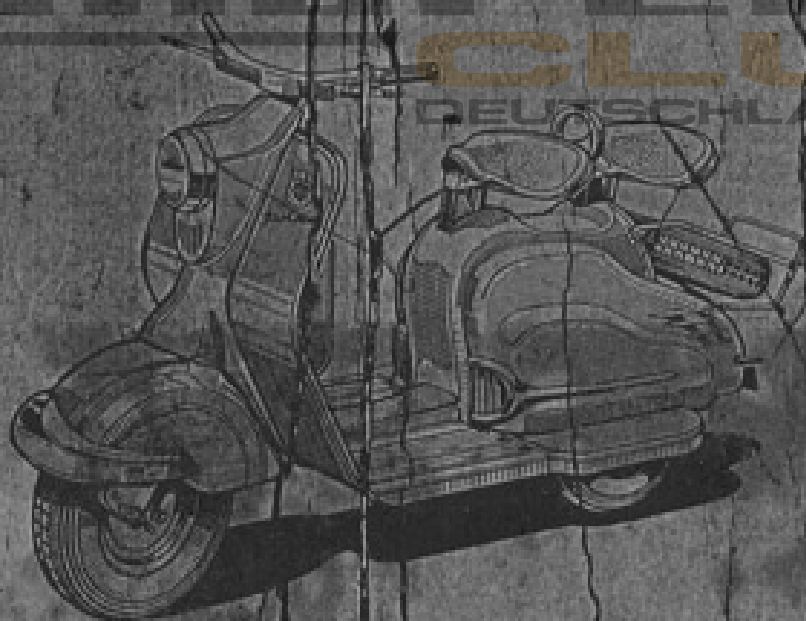



MAINTENANCE MANUAL

NSU-PRIMA 150 cc

Chassis

(Supplementary instructions to Maintenance Manual of december 1955)

MANUEL DE REPARATION

NSU-PRIMA 150 cmc

Châssis

(Instructions supplémentaires pour le Manuel de Réparation du mois de Décembre 1955)

MONTAGEHANDLEIDING

NSU-PRIMA 150 cc

Chassis

(Aanvulling, behorende bij de werkplaatshandleiding, uitgave December 1955)

NSU WERKE AKTIENGESELLSCHAFT, NECKARSULM

FRAME

The term SW indicates the size in mm across the flats of the spanner required.

Special tools required:

See illustrated sheet of special tools. Also C-spanner 078 791 004, which forms part of the tool kit provided with the vehicle, or a suitable commercially-available C-spanner.

Removing and Fitting Front Wheel

(F 01)

1. Loosen the lock nut, and screw the adjuster for the brake cable, which is situated on the brake lever, right in. Disconnect the nipple from the front brake cam lever. Unscrew both nuts on the front axle (20 mm SW) and take out the wheel.
2. Replace in the reverse order. Note that the thin washer is fitted on the left-hand side of the wheel inside the pivoted fork link.



Fig. F 01/1

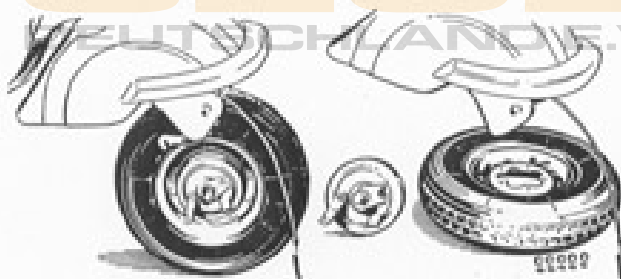

Fig. F 01/1a

Removing and Fitting Rear Wheel

(F 02)

1. Take off left-hand side panel. Unscrew cap nuts (14 mm SW) and lock washers, and take out wheel.
2. Replace in the reverse order.

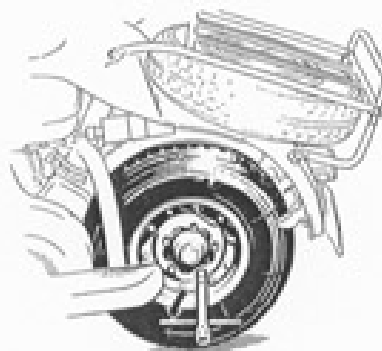

Fig. F 02

Ball Bearing and Seal Rings in Front Hub. Removal and Fitting

(F 03)

1. Remove front wheel from frame (see F 01).
 Remove brake back plate (see F 04).
2. Knock out the axle from the brake drum side, using a rubber hammer. Take off the spacer bushes. Knock out the sealing rings, and remove the circlips. Pull out the ball bearing with a suitable commercial extractor, or knock out with a suitable punch, pushing the spacer tube to one side.
3. Fitting: Press in the left-hand ball bearing. Fit the circlip and fill with grease. Insert the spacer tube, and press in the right-hand ball bearing. Insert the spacer bushes in the sealing rings so that on the left-hand side of the hub the lip on the sealing ring faces **outwards** towards the collar on the spacer bush; on the brake-drum side, on the other hand, the lip must point **inwards**. Push spacer bushes complete with oil seals into hub with the collar on the bush pointing outwards. Knock the axle in carefully from the brake-drum side, so that the left-hand spacer bush is not pushed out of the sealing ring. Fit the brake back plate. Screw on and tighten up both nuts (19 mm SW). Make sure that the axle projects by the same amount on either side.

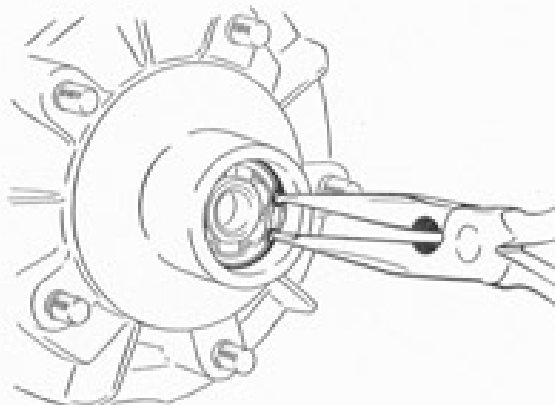

Fig. F 03/2

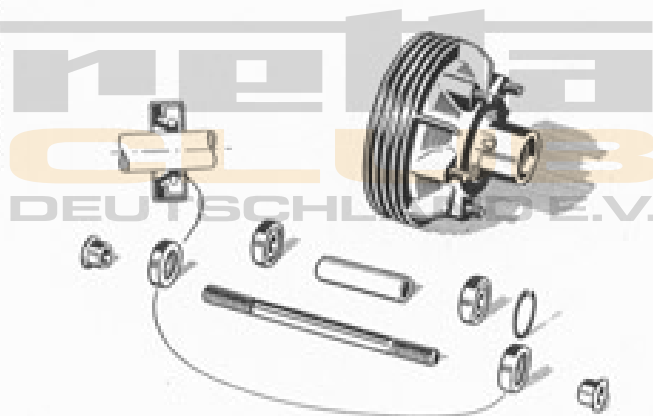

Fig. F 03/2a

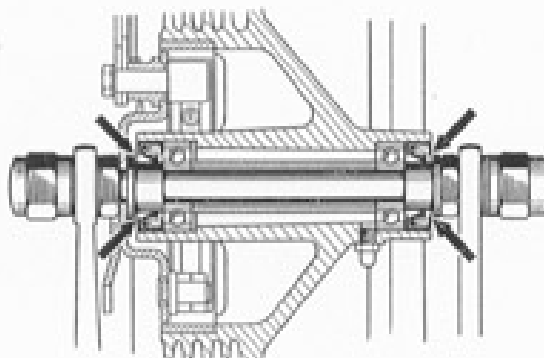

Fig. F 03/3

Brake Back Plate on Front Wheel. Removal and Fitting

(F 04)

1. Remove front wheel from frame (see F 01).
2. Unscrew nut (19 mm SW) on brake back plate, and take off back plate together with brake shoes.
3. Replace in the reverse order.

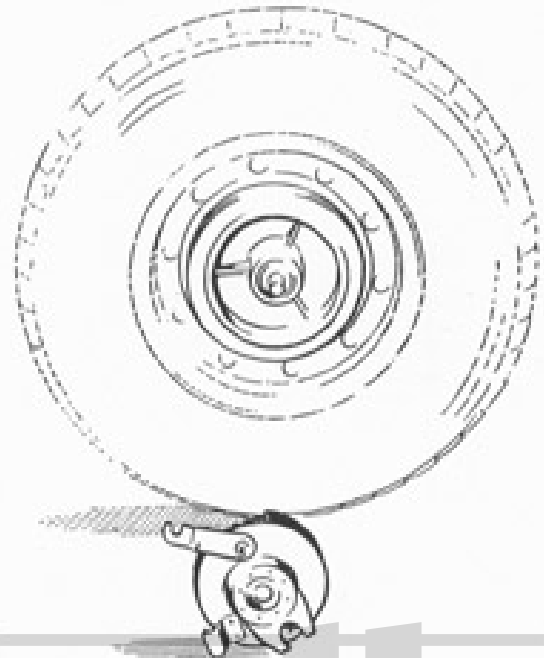

Fig. F 04

Rear Hub. Removal and Fitting

(F 05)

1. Remove rear wheel from frame (see F 02).
2. Unscrew central nut (32 mm SW) and remove lock washer. Pull off hub with extractor (018 099 743).
3. Fitting: The cones must be free from oil and grease when they are assembled. Fit the Woodruff key, attach the hub, and secure with central nut and lock washer.

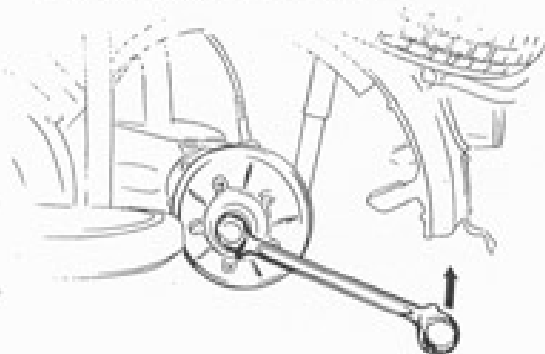

Fig. F 05/2

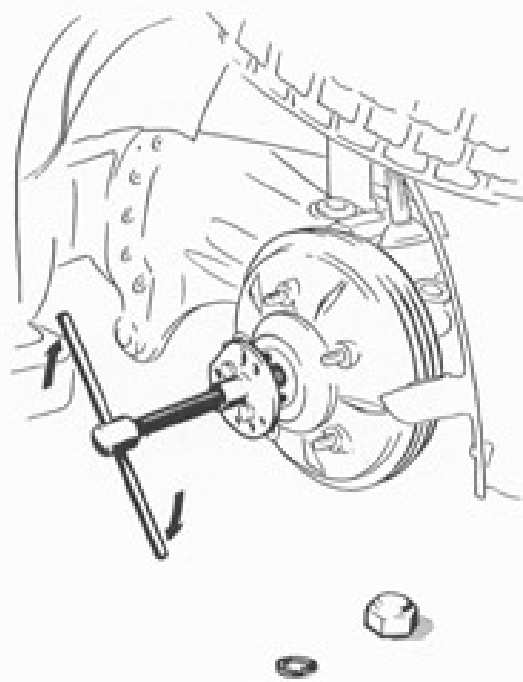

Fig. F 05/2a

Renew Brake Linings (each hub)
(F 08)

Front or rear brake

1. Remove front wheel (see F 01).
Remove front-wheel brake back plate (see F 04).

or

Remove rear wheel (see F 02)
Remove rear hub (see F 05)

2. Remove circlip from pivot pin. Lift off brake shoes and return spring. Clamp brake shoe in vice, holding it by the eye (use protective jaw clamps). Knock off rivets with a chisel.
3. When riveting on the new linings, insert and clench over the central rivets first. Oil the brake cam. Attach the return spring to both brake shoes, and fit shoes. Fit the circlip.

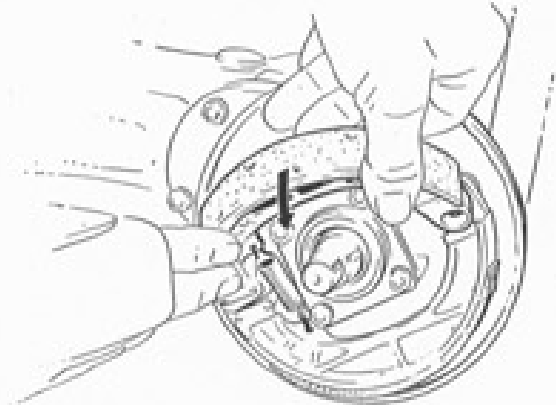

Fig. F 08/2a



Fig. F 08/2

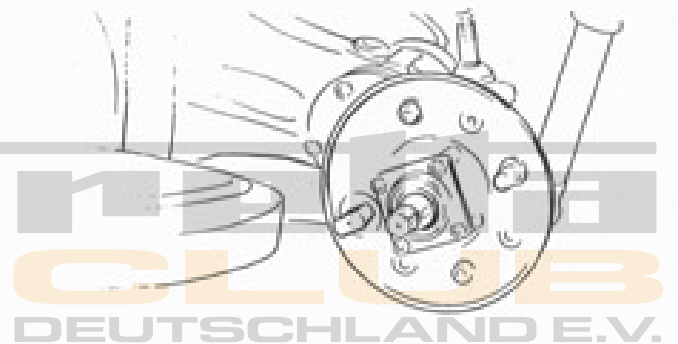

Fig. F 08/2b

Speedometer Drive. Removal and Fitting
(F 09)

1. Remove rear wheel (see F 02).
Remove rear hub (see F 05).
2. Take off cover for swinging arm (see M 02, Section 30).
Remove spiral gears (see M 02, Section 31 and 32).

3. Replace in the reverse order.

Front Forks. Removal and Fitting

(F 20)

1. Remove front wheel (see F 01).
2. Remove the cover plate with the insignia and the rubber base plate. Unscrew the bolt (17 mm SW) which is under the cover plate and remove together with lock washer. Use bolt (11 91 00 934) to pull off the handlebars. Take off the handlebars, and rest them on a clean piece of rag (take care not to damage the paintwork or the control cables). Hold the bearing ring with spanner (11 91 00 128), and unscrew the adjusting nut by means of the C-spanner (128 052 134). Unscrew the bearing ring and remove the front forks. **Take care not to lose the balls out of the ball bearings.**
3. Fitting: Grease the bearing cups and insert the balls (35 1/8" balls in the upper bearing, and 23 1/4" balls in the lower bearing). Fit the front forks with the hand-brake cable, and turn to the left or to the right. Screw in the bearing ring and lock with the adjusting ring. The special spanner (048 422 003) can be used for this. **Make sure that, while there is no play in the forks, they can turn easily to either side.** Fit the handlebars - the cones must be free from oil and grease - and lightly screw up the bolt (17 mm SW), under the head of which there should be a lock washer. The handlebars must be fitted exactly at right angles to the front wheel. Connect up the control cables. Fit the front wheel.

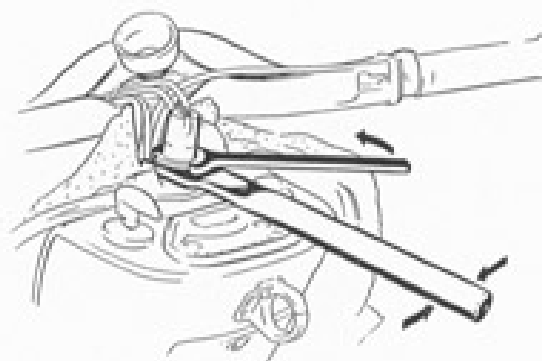

Fig. F 20/2a

netta
CLUB
DEUTSCHLAND E.V.

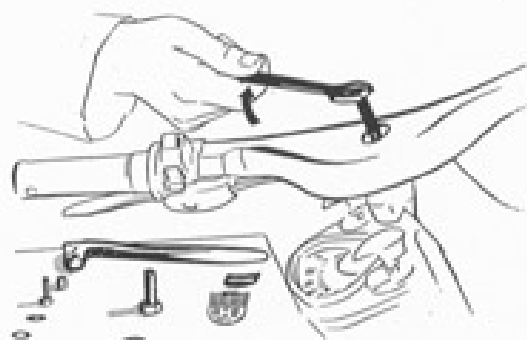

Fig. F 20/2



Fig. F 20/2b

Steering-Head Cones, Cups, and Balls. Removal and Fitting

(F 21)

1. Remove the front wheel (see F 01).
Remove the front forks (see F 20).
Remove the fork cowling (see F 30).
2. Knock the upper and lower steering-head races out of the steering head by means of a suitable tube inserted inside the steering head. Knock the lower cone off the fork stem by means of a punch passed up from underneath through the two holes.
3. Fitting: Knock the races into position in the steering head. Press the lower cone onto the fork stem by means of a suitable tube pushed over the stem. Fit the front forks and the front wheel.

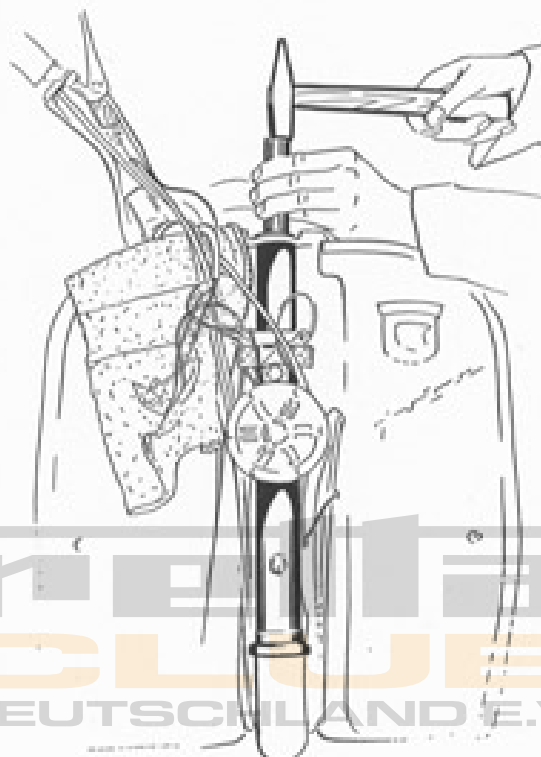

Fig. F 21/2a

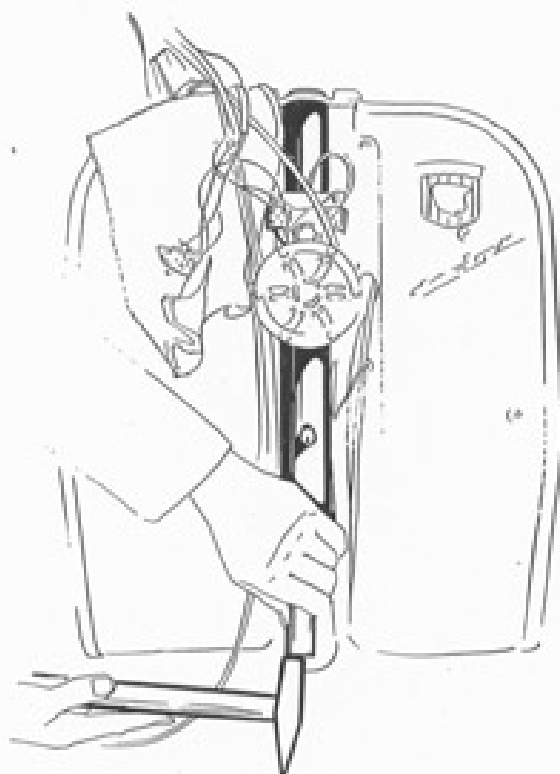

Fig. F 21/2

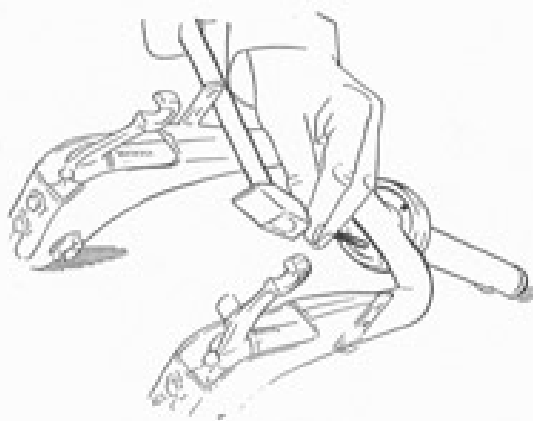

Fig. F 21/2b

Lambretta
CLUB
DEUTSCHLAND E.V.

Front Fork Springs. Removal and Fitting

(F 22)

1. Remove the front wheel (F 01).
2. Unscrew the bolts (10 mm SW) on the under side of the forks, together with their washers and lock washers. Push the pivoted link slightly upwards, and remove the buffer. Unscrew the hexagon nut (19 mm SW) on the inside of the forks and remove together with its lock washer. Knock out the pivot bolt with the aid of

a brass punch. Take off the pivoted link complete with caps, bush, spring guide rod, spring, cap, and bearing bush.

3. Replace in the reverse order. Grease the springs and their guide rods.



Fig. F 22/2

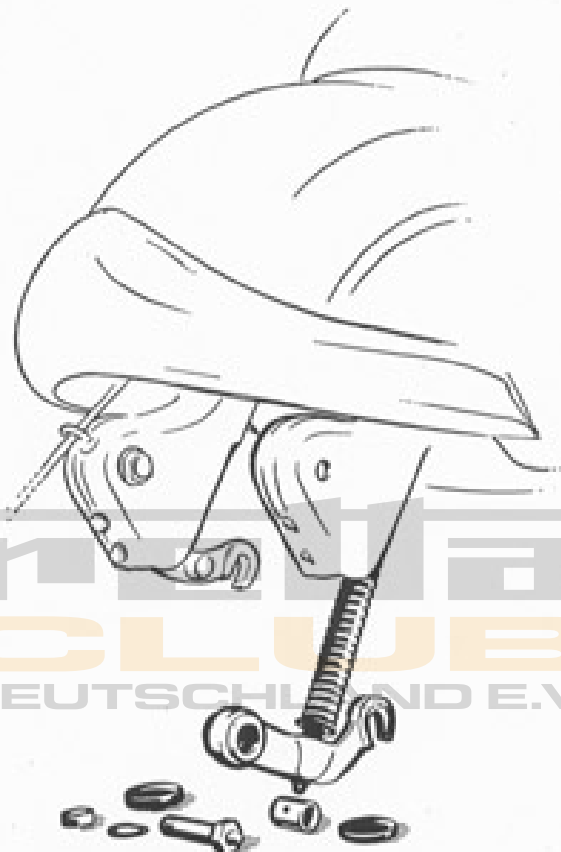

Fig. F 22/2a

Pivoted Links, Left-hand and Right-hand Removal and Fitting

(F 24)

1. Remove the front wheel (see F 01).
Remove the pivoted links (see F 22).
2. Replace in the reverse order.

Replacing Bushes in Pivoted Links

(F 25)

1. Remove front wheel (see F 01).
Remove pivoted links (see F 24).
2. Use a suitable punch to knock out the bearing bushes. Press in new bushes, and open them up with an adjustable reamer so that the spacer bush moves easily inside them.
3. Replace in the reverse order.

Front Mudguard. Removal and Fitting

(F 26)

1. Remove the front wheel (see F 01).
Remove the front forks (see F 20).
2. Unscrew three bolts (10 mm SW) on the inside of the mudguard, and remove together with the lock washers. Loosen the bolt (9 mm SW) on the clip, and take off the mudguard.
3. Replace in the reverse order. The open end of the mounting clip must be at the front.

Front Bumper. Removal and Fitting

(F 27)

1. Unscrew the three bolts (10 mm SW) on the inside of the mudguard and remove together with the lock washers. Take off the bumper.
2. Replace in the reverse order.

Fork Cowling. Removal and Fitting

(F 30)

1. Remove the headlamp (see E 13).
2. Unscrew the two countersunk screws inside the headlamp cavity and the four countersunk screws on the rear of the leg shield. Place a rag between the fork cowling and the mudguard, and carefully lift off the fork cowling together with the rubber mouldings on either side.
3. Replace in the reverse order. Position the control cables so that the throttle cable lies on the left-hand side of the horn, and the clutch, gear-change, and front-brake cables on the right-hand side of the horn. Make sure the rubber mouldings fit properly.

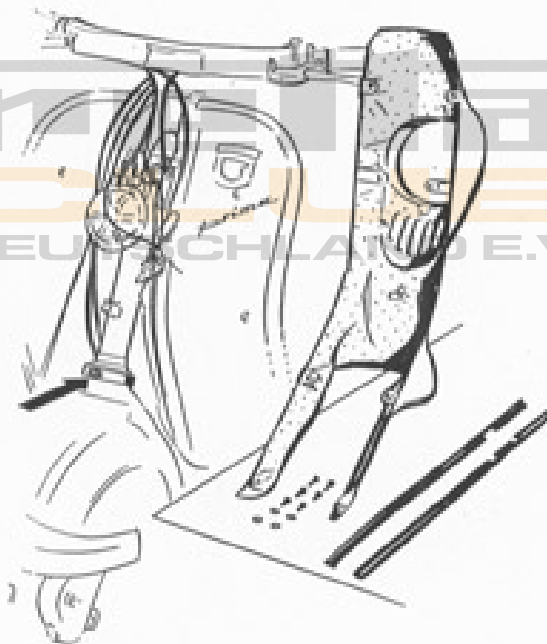

Fig. F 30

Handlebars and Fittings. Removal and Fitting

(F 40)

1. Disconnect brake cable (see F 51).
Disconnect throttle cable (see F 53).
Disconnect clutch cable (see F 50).
Disconnect gear-change cable (see F 54).
Remove headlamp (see E 13).
Remove dip-switch lead (see E 05).
2. Take off the cover plate with the insignia and the rubber base plate. Unscrew the bolt (17 mm SW), and pull off the handlebars with the aid of bolt (11 91 00 934).
3. Replace in the reverse order. Follow the wiring diagram when connecting up the electric leads.

Handlebar Bend. Stripping and Assembly
(F 41)

1. See F 40.
Remove dip-switch (see E 10).
Remove gearchange twistgrip (see F 46).
2. Replace in the reverse order. When tightening up the tapered bolt under the dip-switch, make certain that the gearchange twistgrip can be turned easily.

Speedometer. Removal and Fitting
(F 42)

1. Open the battery box, and disconnect the earth lead (10 mm SW).
2. Open the lid on the instrument panel, and unscrew the knurled nut on the speedometer driving shaft. Pull out three bulbs (charging indicator lamp, speedometer illumination lamp, fuel gauge lamp) complete with bulb holders and leads. Push the speedometer downwards slightly to free the round nuts. Unscrew the round nuts and remove together with the clips. Pull the speedometer out from the top.
3. Replace in the reverse order. Finally connect earth lead.

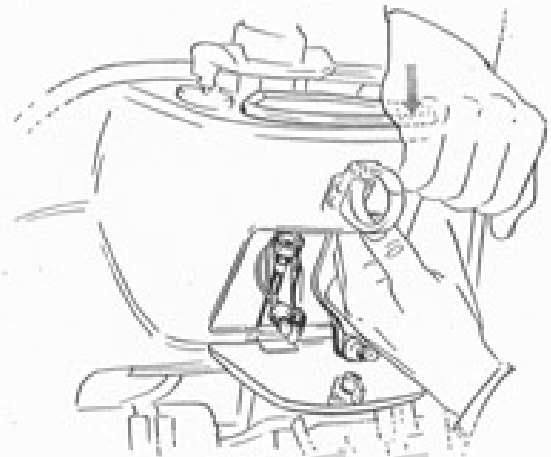

Fig. F 42/2a



Fig. F 42/2

Prima
CLUB
DEUTSCHLAND E.V.

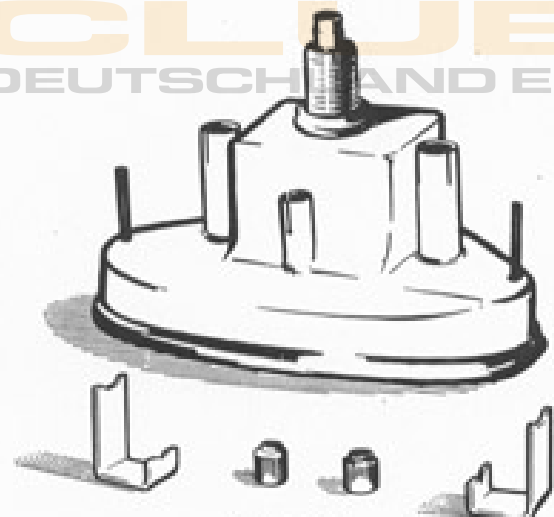

Fig. F 42/2b

Speedometer Drive Shaft. Removal and Fitting
(F 43)

1. Remove the fork cowling (see F 30).
Remove the battery box (see E 16).
Remove the instrument panel (see E 19).
Remove edge strips, left-hand and right-hand (see F 83).
2. Unscrew six nuts (7 mm SW) on the bottom of the leg shield at the front. Take off the right-hand side panel. Loosen the hexagon-head bolt (10 mm SW) on the swinging arm and pull out the speedometer drive shaft. Remove the rubber cap. Unscrew the knurled nut on the speedometer. Open the three cable clips on the frame. Push the leg shield slightly to the rear and at the same time pull the speedometer drive shaft out from the top.
3. Replace in the reverse order.

Brake and Clutch Lever. Removal and Fitting

(F 44)

1. Disconnect the nipple on the brake cable from the brake cam lever on the brake back plate. Unscrew the pivot bolt (9 mm SW) and remove with washer and cup washer. Push the hand lever towards the handlebars and pull the lever out of its mounting. Disconnect the brake cable.
2. Disconnect the nipple on the clutch cable from the clutch-operating lever on the engine. Disconnect the nipple from the hand lever on the handlebars. Unscrew the nut (10 mm SW) and remove with the star washer, and then unscrew the pivot bolt. Take off the hand lever.
3. Replace in the reverse order.
On the hand brake lever the cup spring must be fitted with its raised centre bearing against the head of the bolt.

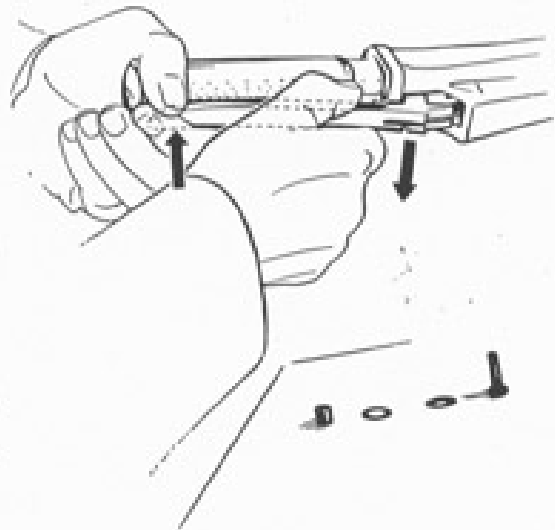

Fig. F 44

Lambretta

CLUB
EUTSCHLAND E.V.

Throttle Twistgrip. Removal and Fitting

(F 45)

1. Push the rubber sleeve back slightly. Unscrew the countersunk screw. Take off the end cap. Turn the twistgrip away from you, at the same time pulling it off the handlebars.
2. Replace in the reverse order.

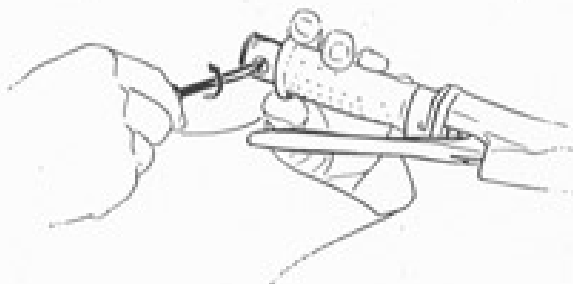

Fig. F 45/1

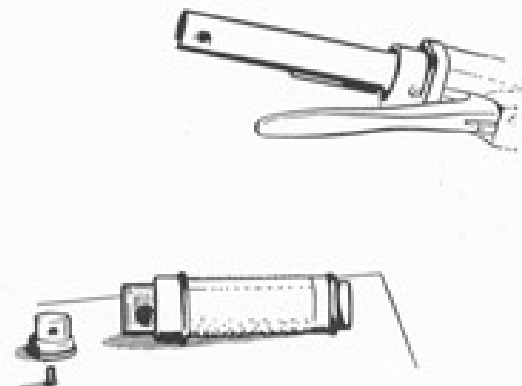

Fig. F 45/1a

Gearchange Twistgrip. Removal and Fitting
(F 46)

1. Engage second gear, and unscrew the counter-sunk screw in the twistgrip. Engage third gear. Disconnect the clutch cable from the engine and from the handlebar lever. Take off the end cap and the washer. Unscrew the counter-sunk screw on the underside of the twistgrip body and remove together with the star washer. Take off the cap. Remove the segment with the gearchange cable, and pull off the twistgrip.
2. Replace in the reverse order, with third gear engaged. The mark on the segment must be in line with the mark on the twistgrip body.

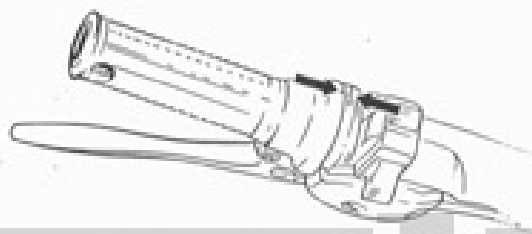

Fig. F 46/1

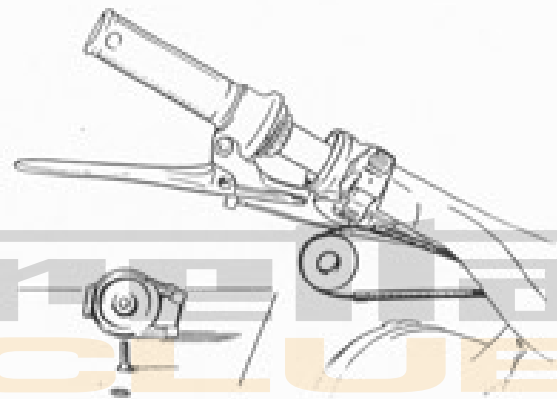

Fig. F 46/1b

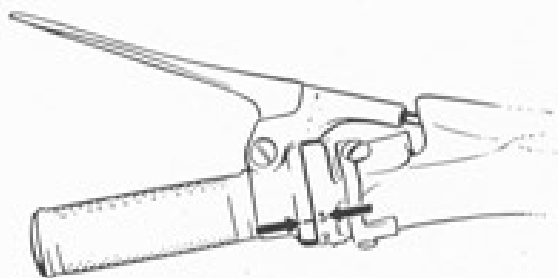

Fig. F 46/1a

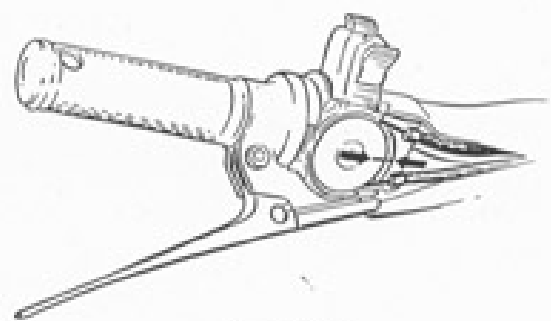

Fig. F 46/2

Sleeve on Twistgrip or Dummy Grip. Removal and Fitting
(F 47)

1. Lift the interior of the sleeve with a small screwdriver. Squirt a few drops of petrol between the sleeve and the grip, and pull the sleeve off with a twisting motion.
2. Assembly: Moisten the sleeve with petrol, and push it on quickly with a twisting motion.

Twistgrip Slider. Removal and Fitting

(F 48)

1. Take off the throttle twistgrip (see F 45).
2. Unscrew the top cap of the carburettor, and carefully lift out the throttle slide. Disconnect the throttle cable from the throttle slide and the twistgrip slider. Remove the twistgrip slider.
3. Replace in the reverse order.

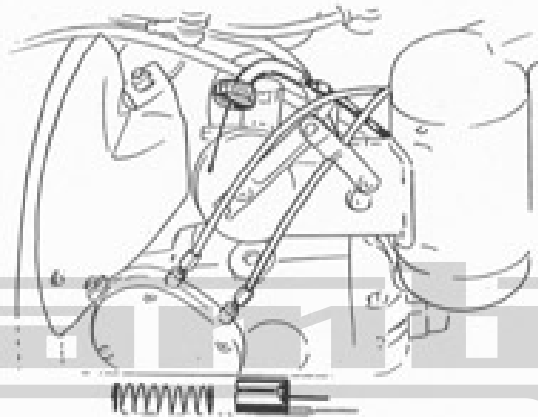

Fig. F 48/2



Fig. F 48/2a

Clutch Cable. Removal and Fitting

(F 50)

1. Remove the headlamp (see E 13).
Remove the fork cowling (see F 30).
2. Disconnect the clutch cable from the clutch-operating lever on the engine. Unscrew the adjuster, and disconnect the nipple from the hand lever.
3. Fitting: Connect the ends of the old and new cables together by twisting a piece of wire round them. Loosen the clips on the frame slightly, and draw in the new cable by pulling out the old one. Screw in the adjuster and connect the nipples. Remove any excessive play by means of the adjuster and lock nut.

Front Brake Cable. Removal and Fitting

(F 51)

1. Remove the headlamp (see E 13).
Remove the fork cowling (see F 30).
2. Disconnect the nipples from the brake cam lever and the hand lever.
3. Fitting: Connect the ends of the old and new cables together by twisting a piece of wire round them. Draw in the new cable by pulling out the old one. Connect the nipples. Remove any excessive play by means of the adjuster on the hand lever. Tighten up the lock nut on the adjuster.

Cable for Gearchange Locking Mechanism. Removal and Fitting

(F 52)

1. Lift the rubber mat on the right-hand footrest, and unscrew the countersunk screw on the silencer. Unscrew four nuts (9 mm SW), together with lockwashers, and take off footrest. Unscrew the countersunk screws on the gearchange casing, and take off the cover complete with gasket. Loosen the lock nut (10 mm SW) on the adjusting screw and unscrew the adjusting screw completely (9 mm SW). Disconnect the cable from the clutch lever.

Unscrew the bolt (10 mm SW) on the ratchet plate with its lock washer and washer, and prise off the ratchet plate with a screwdriver.

Unscrew the plug (14 mm SW). If this is not done the spring will be damaged.

Disconnect the locking pin from the nipple of the cable. Remove spring, plug, and cable.

2. Fitting: Assemble cable, plug, spring, and locking pin, and screw into gearchange casing. When fitting the ratchet plate, pull back the locking pin by means of the cable. Insert the outer casing of the cable in the eye formed in the clutch cover. Screw the adjuster into the clutch operating lever, and lock it. **The adjuster of the gearchange locking cable should be set so that there is a play of about 2—3 mm (0.08—0.12") when the clutch lever is released. If the play is less than this there is the danger either that the clutch will not disengage properly or that the nipples will be pulled off the gearchange locking cable.**

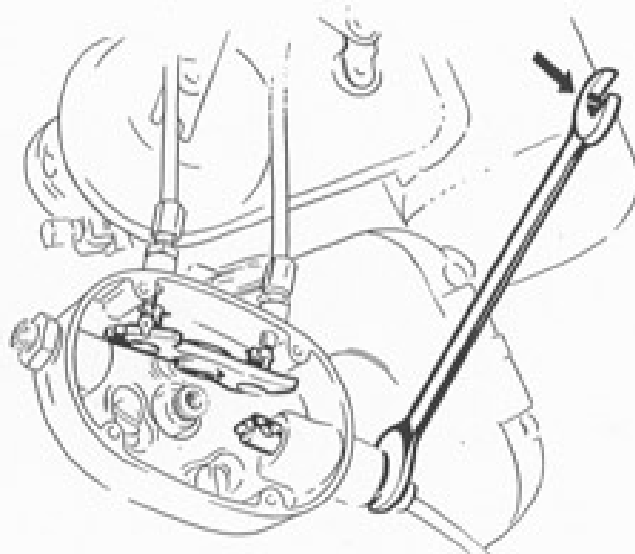

Fig. F 52/1

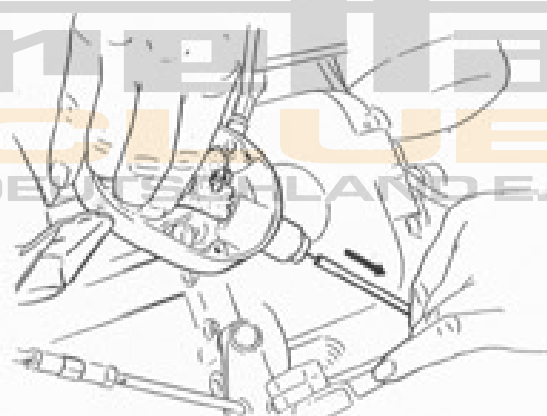

Fig. F 52/2

Throttle Cable. Removal and Fitting

(F 53)

1. Remove the throttle twistgrip (see F 45). Remove the slider from the twistgrip (see F 48). Remove the fork cowling (see F 30).
2. Loosen the cable clips on the frame.
3. Fitting: Connect the ends of the old and new cables together by twisting a piece of wire round them, and draw in the new cable by pulling out the old one. Finally attach the nipple to the throttle slide.

Gearchange Cable. Removal and Fitting
(F 54)

1. Remove the fork cowling (see F 30).
Remove the gearchange twistgrip (see F 46).
2. Take the cover off the gearchange casing (see F 52). Remove the split pins from the pivot pin. Screw the cable adjusters right in and disconnect the nipples. Unscrew the adjusters, loosen the cable clips on the frame, and pull the cable out in an upward direction.
3. Fitting: Insert the cable from the front, and attach it to the gearchange twistgrip first (see F 46). Engage bottom gear, and screw the adjuster of the shorter cable into the front

hole of the gearchange casing and that of the longer cable into the rear hole. Attach both nipples and fit the split pins.

Engage second gear (both with the gearchange twistgrip and with the gearchange mechanism) and screw in both adjusters until there is no play in the cable. Tighten up the lock nuts on the adjusters Grease the ratchet plate. Adjust the gearchange mechanism (see M 02, section 29).

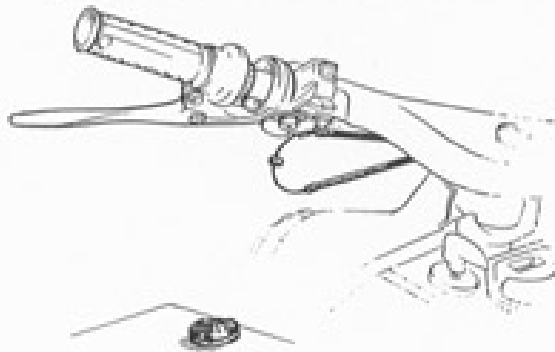

Fig. F 54/2

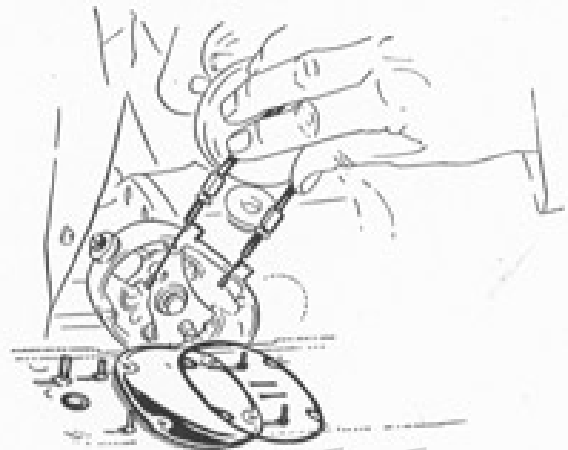

Fig. F 54/3

Cable for Strangler and Tickler Operation. Removal and Fitting
(F 55)

1. Remove the headlamp (see E 13).
Remove the fork cowling (see F 30).
2. Unscrew the bolt (9 mm SW) and take off the inlet air silencer. Remove the split pin from the tickler. Pull out the lever. Unscrew the cable adjuster. Pull up the knob on the guide rod. Hold the guide rod with a pair of pliers and unscrew the knob. Open the glove locker. Loosen the nut (17 mm SW) and unscrew the knurled nut. Pull out the sleeve and the cable. Take off the hexagon nut and the bracket. Loosen the clips on the frame, and pull the cable out downwards.
3. Fitting: Insert the cable from the engine side between the frame and the legshield, and pass it through the upper hole in the legshield. Screw the hexagon nut, the bracket, and the knurled nut onto the sleeve of the cable. Fit the knob onto the guide rod. Screw in the adjuster. Connect the lever to the tickler by means of a split pin. Adjust the cable by means of the adjuster, and tighten up the lock nut.

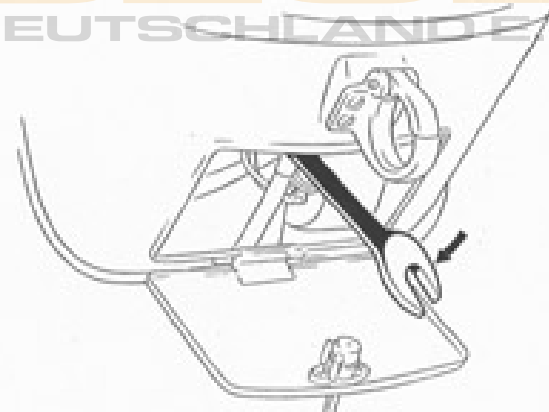

Fig. F 55/2a

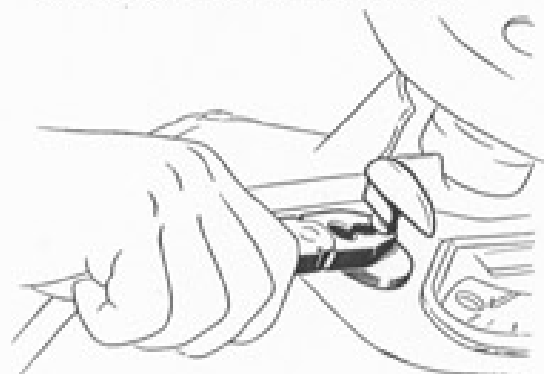

Fig. F 55/2

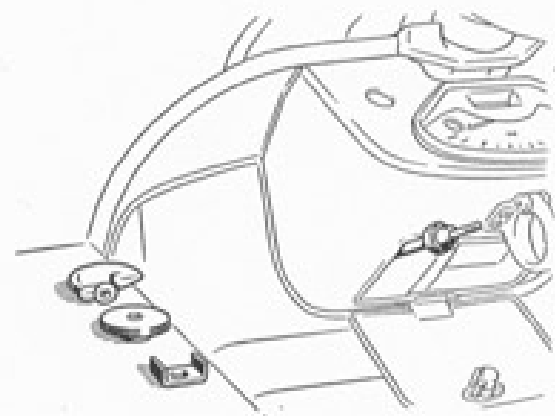

Fig. F 55/2b

Frame. Removal and Fitting

(F 60)

- | | |
|---|------------|
| 1. Remove engine | (see M 01) |
| Remove front wheel | (see F 01) |
| Remove front forks | (see F 20) |
| Remove steering-head cones, cups,
and balls | (see F 21) |
| Remove headlamp | (see E 13) |
| Remove fork cowling | (see F 30) |
| Remove gearchange twistgrip | (see F 46) |
| Remove clutch cable | (see F 50) |
| Remove front brake cable | (see F 51) |
| Remove cable for gearchange
locking mechanism | (see F 52) |
| Remove gearchange cable | (see F 54) |
| Remove cable for strangler
and flicker operation | (see F 55) |
| Remove pillion saddle | (see F 71) |
| Remove saddle | (see F 72) |
| Remove rear light | (see E 09) |
| Remove front central panelling section | (see F 61) |
| Remove fuel tank | (see F 80) |
| Remove rear central panelling section | (see F 63) |
| Remove instrument panel | (see E 19) |
| Remove battery | (see E 15) |
| Remove battery box | (see E 16) |
| Remove legshield | (see F 90) |

Front Central Section of Panelling. Removal and Fitting

(F 61)

1. Remove pillion saddle (see F 71).
Remove saddle (see F 72).
2. Unscrew two bolts (14 mm SW) on front of luggage carrier and remove with lock washers and spacer tubes. Hinge the luggage carrier up to the rear and remove the spare wheel. Take off both side panels. Remove the split pin on the universal joint for the fuel tap and filter, and pull the control rod out to the front. Unscrew four countersunk screws with washers and two nuts (10 mm SW). Take out rubber grommets. Lift the central section of the panelling off carefully.
3. Replace in the reverse order.

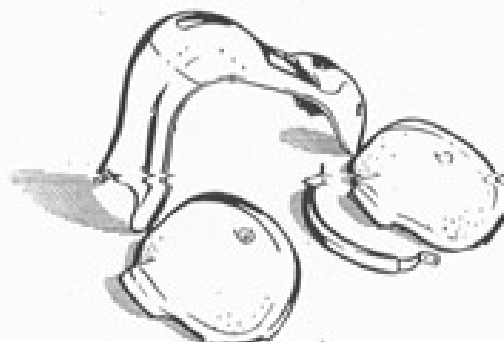
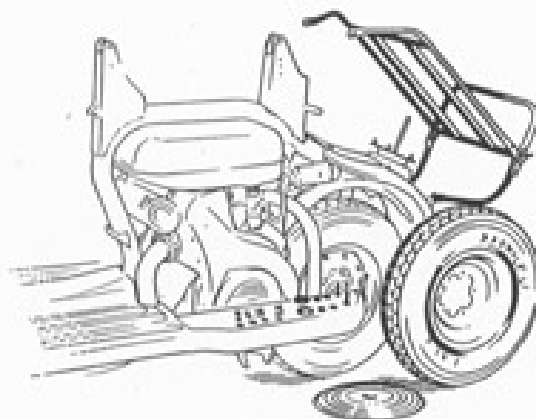

Fig. F 61

Rear Mudguard. Removal and Fitting

(F 62)

1. Remove the rear wheel (see F 02).
2. Unscrew the front and rear mounting bolts. Bend up the clip for the leads on the mudguard. Take off the mudguard.
3. Replace in the reverse order.

Rear Central Section of Panelling. Removal and Fitting

(F 63)

1. Remove front central section of panelling (see F 61).
Remove rear and stop lights (see E 09).
Remove saddle (see F 72).
Remove pillion saddle (see F 71).
2. Unscrew six bolts (10 mm SW) with lock washers and nuts, one bolt (11 mm SW) with lock washer and nut, and one countersunk screw with washer, lock washer, and nut from rear central portion of panelling. The luggage carrier, the spare wheel holder, and the ignition coil can then be removed and the rear central section of the panelling can be lifted off.
3. Replace in the reverse order.

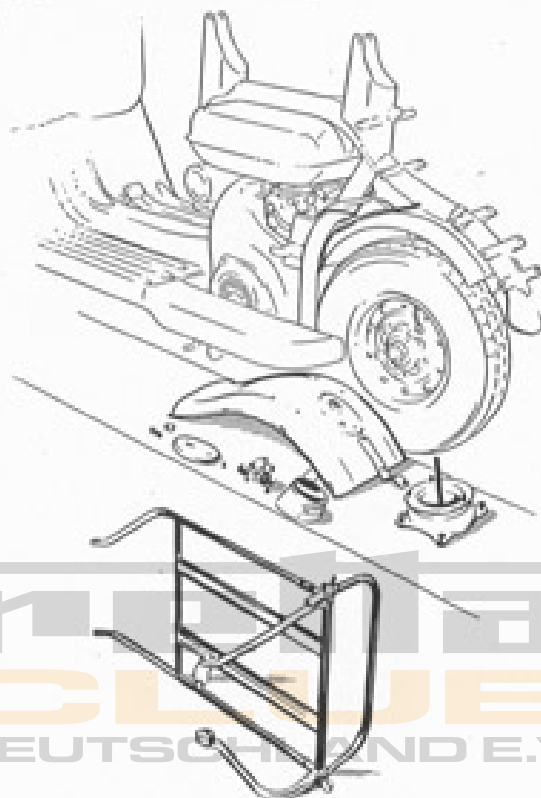

Fig. F 63

Rear Shock Absorber. Removal and Fitting

(F 65)

1. Unscrew mounting bolt (14 mm SW) on swinging arm. Take off locking wire on mounting bracket. Remove shock absorber.
2. Replace in the reverse order.

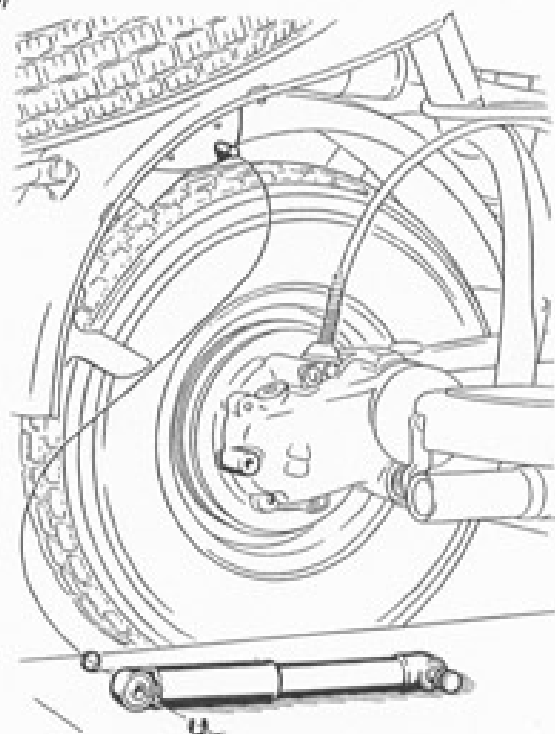

Fig. F 65

Rear Springing. Removal and Fitting

(F 67)

1. Remove rear wheel (see F 02).
Remove rear hub (see F 05).
2. Remove circlip on left-hand end of bearing pin. Knock out bearing pin with a punch; the rear spring unit will then drop down. Take the split pin off the brake cam lever and pull out the pin. For remaining work see M 02, section 22—25.
3. Replace in the reverse order.

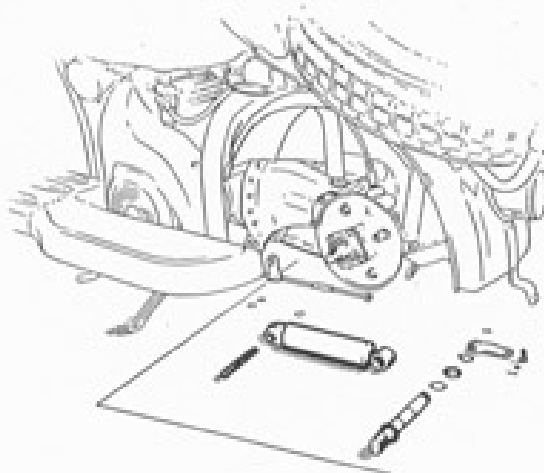

Fig. F 67

Bush for Rear Spring Unit and Bearing Pin. Removal and Fitting

(F 68)

1. Remove rear wheel (see F 02).
Remove rear hub (see F 05).
Remove rear spring unit (see F 67).
2. Force the defective bearing bush out of the connection lug and the pull rod. Press in a new bush, and ream out to size. Use an adjustable reamer. If the mounting holes in the transmission casing are worn, they should also be reamed out, and a larger bearing pin fitted (see Spare Parts List. Bearing pins available from 14 to 15.5 mm dia).

CLUB
DEUTSCHLAND E.V.

Exhaust System. Removal and Fitting

(F 70)

1. See M 01, sections 4 and 22.

Pillion Saddle. Removal and Fitting
(F 71)

1. Unscrew bolts (10 mm SW) and lock washers on hand grip, and remove hand grip. After unscrewing two nuts (14 mm SW) with star washers, washers, and spacer bushes, lift off the saddle cover. Unscrew nut (14 mm SW) on left-hand side of saddle base. Fit assembly tool 11 91 00 935, and press it down. This compresses the spring, and the bolt (14 mm SW) can be screwed out. Take off saddle base with rubber cap, spring casing, and spring.
2. Replace in the reverse order. Grease both ends of the spring. Again compress the spring with the tool 11 91 00 935 to enable the bolt (14 mm SW) to be inserted.



Fig. F 71/1a

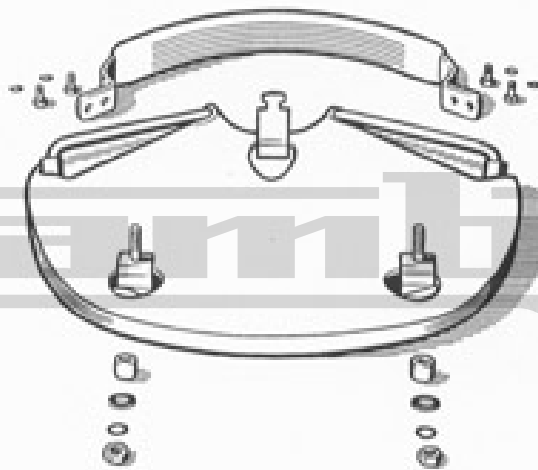

Fig. F 71/1,

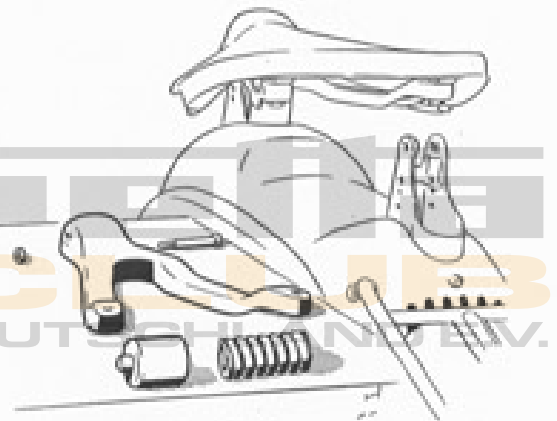

Fig. F 71/1b

Saddle. Removal and Fitting
(F 72)

1. As for F 71, excepting that the hand grip is not fitted.

Prop Stand. Removal and Fitting
(F 73)

1. Remove the split pin and washer from the bearing pin. Drive out the pin with a punch, and remove the prop stand and spring.
2. When fitting, attach the spring to both lugs simultaneously (The long end of the spring should be fitted at the top).

Central Stand and Return Spring. Removal and Fitting
(F 74)

1. See M 01, section 18.

Tool Box. Removal and Fitting

(F 76)

1. Take off left-hand side panel. Unscrew mounting bolt (10 mm SW) with lock washer. Take off tool box.
2. Replace in the reverse order.

Fuel Tank. Removal and Fitting

(F 80)

1. Remove tool box (see F 76).
2. Pull the fuel pipe off the tap. Take the split pin out of the universal joint on the tap, and pull the control rod slightly forwards. Loosen the union nut (19 mm SW), and turn the tap so that it points across the vehicle. Take out the sparking plug. Loosen the pinch bolt (9 mm SW), and pull the inlet air silencer off the carburetter. Disconnect the lead from the fuel gauge tank unit. Unscrew the front bolt (10 mm SW) and the rear bolt (9 mm SW). Lift the fuel tank and rubber out to the right.
3. Replace in the reverse order. Make sure the rubber pad is fitted correctly.

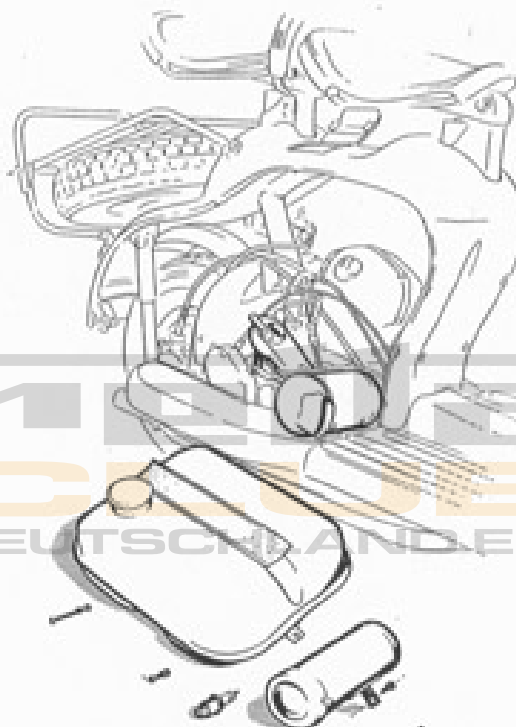

Fig. F 80

Fuel Tap and Filter. Removal and Fitting

(F 82)

1. Take the split pin out of the universal joint on the tap, and push the control rod forwards slightly. Pull off the fuel pipe and unscrew the tap (19 mm SW).
2. Replace in the reverse order.

Edge Strip, Left-hand and Right-Hand, for Legshield. Removal and Fitting

(F 83)

1. Unscrew three grub screws in each edge strip with the aid of a suitable screwdriver. Take off the edge strips.
2. Fitting: Fit the top of the strips first, and screw in the top screw. Then screw in the centre screw and finally the lower one. Make sure that the edge strips fit properly.

Legshield. Removal and Fitting

(F 90)

1. Remove fork cowling (see F 30).
Remove battery (see E 15).
Remove battery box (see E 16).
Remove instrument panel (see E 19).
Remove edge strips on legshield (see F 83).
2. Unscrew two slotted screws with lock washers from the front of the legshield. Unscrew all the nuts (7 mm SW) from the footrests, and also the nut (10 mm SW) and the rubber mounting (24 mm SW) for the silencer. Remove the footrests. Remove the circlip from the brake pedal. Disconnect the return springs. Unscrew two slotted screws and take off the stop-light switch. Jerk the top end of the legshield to the rear, taking the brake pedal out from underneath at the same time, and remove the legshield completely.
3. Replace in the reverse order. The top end of the legshield should be forced slightly to the rear. Fit the brake pedal before securing the legshield.



Fig. F 90

Footrest, Left-Hand and Right-Hand. Removal and Fitting

(F 91)

See M 01, section 3.

ELECTRICAL INSTALLATION

Cable Harness. Removal and Fitting

(E 01. — E 04)

To avoid damage, make a point of first disconnecting the earth lead from the battery.

1. Remove fork cowl (see F 30).
Remove starting, lighting, and ignition switch (see E 18).
Remove cowl (see M 01, section 11).
2. Disconnect the battery leads from the dynamo, the two leads on the cutout, and the red lead (+ve) on the battery. Disconnect the lead for

the rear and stop lights. (see E 09). Disconnect the lead from the stop light switch (see E 14). Loosen the cable clips on the frame and pull the cable harness out to the rear.

3. Fitting. Insert the cable harness from the rear. Connect the leads up in accordance with the wiring diagram. The earth lead should be attached to the battery last of all.

Wiring Diagram

(12 Volt Equipment)

prima

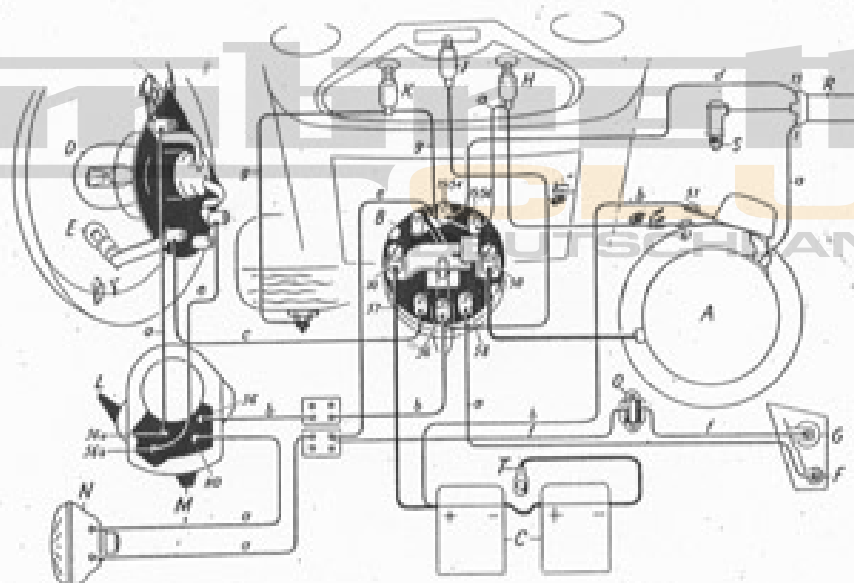

A Flywheel dynamo and starter
B Starting, lighting, and ignition switch
C Battery
D Headlamp bulb (double-filament)
E Parking light bulb
F Rear light bulb

G Stop light bulb
H Dynamo charging indicator bulb
J Speedometer illumination bulb
K Fuel gauge bulb
L Dip-switch
M Horn button

N Horn
O Stop light switch
R Ignition coil
S Sparking plug
T Earth lead connection

a black
b red
c brown
d yellow
e white
f blue
g green

Dip-Switch Lead. Removal and Fitting

(E 05)

1. Remove headlamp (see E 13).
Remove dip-switch (see E 10).
2. Disconnect two leads from the headlamp and two leads from the terminal strip and mark them. Pull the dip-switch lead out of the fork cowl.

3. Replace in the reverse order. Connect up in accordance with the wiring diagram.

Horn. Removal and Fitting

(E 06)

1. Remove headlamp (see E 13).
2. Unscrew bolt (14 mm SW) and lock washer. Disconnect lead, and take off horn.
3. Replace in the reverse order.

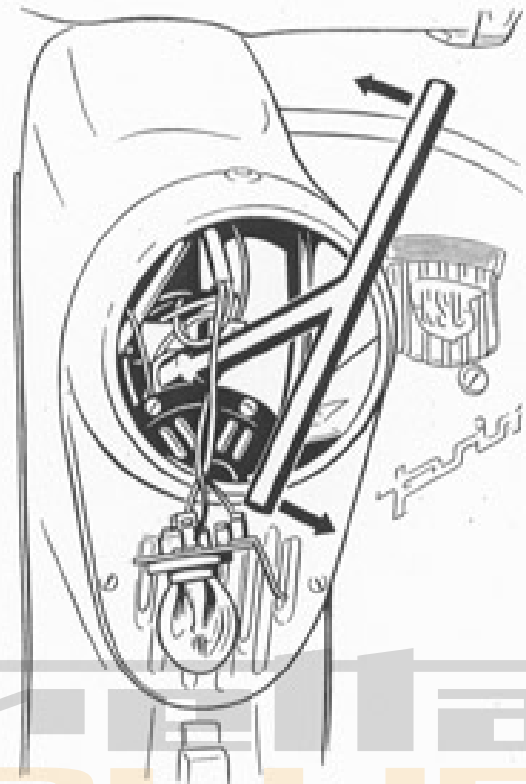

Fig. E 06

Fuel Gauge Tank Unit. Removal and Fitting

(E 07)

1. Push the rubber sleeve back along the lead slightly, and disconnect the lead from the terminal (7 mm SW). Screw the fuel gauge tank unit out of the tank (19 mm SW).
2. Replace in the reverse order.

Reflector and Rear Light. Removal and Fitting

(E 09)

1. Unscrew the mounting bolt (7 mm SW) on the cap, and remove the cap. Disconnect the leads. Unscrew two nuts (9 mm SW) and lock washers on the inside of the rear central section of the panelling and remove the base.
2. Replace in the reverse order.

Dip-Switch. Removal and Fitting

(E 10)

1. Unscrew the countersunk screw on the dip-switch and remove the switch. Carefully push the switch out of its casing. Disconnect the lead and mark it.
2. Replace in the reverse order.



Fig. E 10

Headlamp Glass and Reflector. Removal and Fitting

(E 13)

1. Remove the headlamp (see E 13).
2. Bend up the clips on the glass mounting ring, and take out the glass, reflector, seal ring, and glass mounting ring as a unit.
3. Fitting: Insert the headlamp glass (with inscription "oben" at top) and fit the reflector so that the parking lamp is on top. Bend over all the clips, and replace the headlamp.

DEUTSCHLAND E.V.

Headlamp. Removal and Fitting

(E 13)

1. Unscrew two countersunk screws and caps, and take out the headlamp. Disconnect the spring, and take out the bulb holder and bulb.
2. Replace in the reverse order.

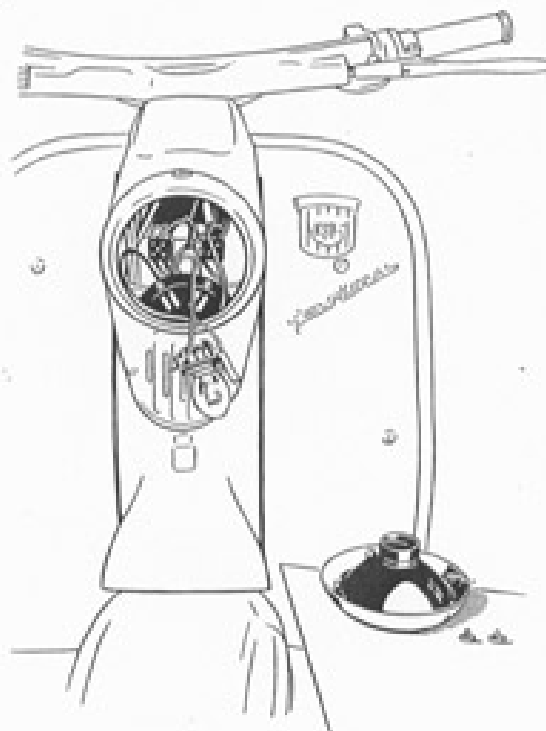

Fig. E 13

Stop Light Switch. Removal and Fitting

(E 14)

1. Remove two cheesehead bolts and lock washers. Take the protective cap off the switch, and disconnect the leads.
2. Replace in the reverse order. Make sure the switch is in the correct position.

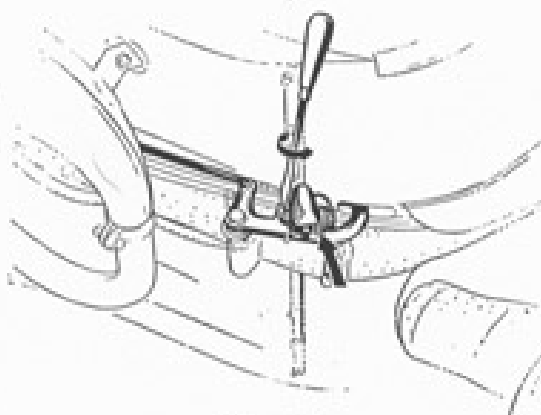

Fig. E 14

Battery. Removal and Fitting

(E 15)

1. Unscrew the knurled bolt and take off the lid of the battery box. Unscrew the earthing bolt on the frame. Push up the clips on the battery holders with a screwdriver. Push the battery holder and battery to the right or left, and take out. Remove the metal straps. Disconnect the positive lead and dynamo lead (red).
2. Replace in the reverse order.

The leads should be connected to the terminals of the batteries before these are fitted in the battery box. The earth lead must not be bolted to the frame (with the spade terminal pointing upwards) until after the battery has been fitted in the battery box, and must be passed over the top of the battery (see wiring diagram and Fig. E 15/2).

Make sure that there is good contact at all the electrical connections. Place the battery in the holder and fit the straps. Insert the assembled battery and holder in the battery box, and secure the clips. Secure the lid with the knurled bolt.

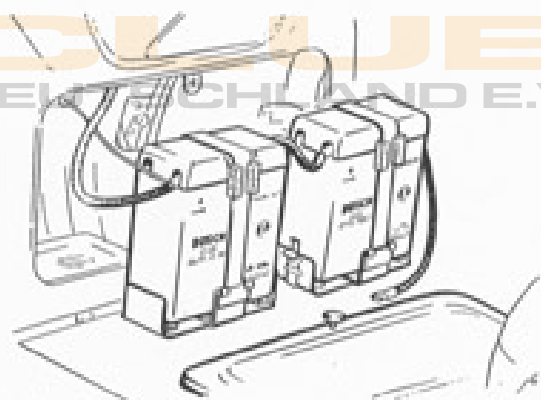

Fig. E 15/1

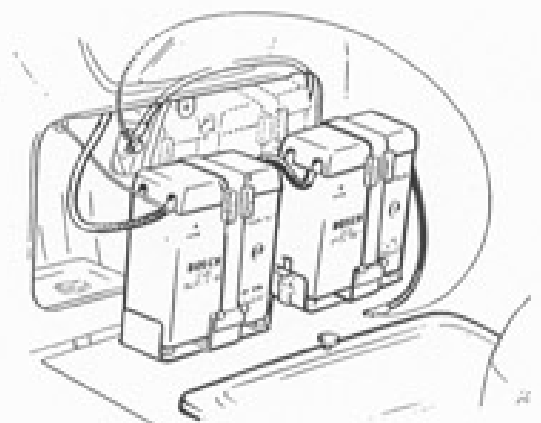

Fig. E 15/2

Battery Box. Removal and Fitting
(E 14)

1. Remove the battery (see E 15).
2. Unscrew four bolts and washers on the front of the legshield, and two bolts and washers on the rear. Remove the battery box.
3. Replace in the reverse order.

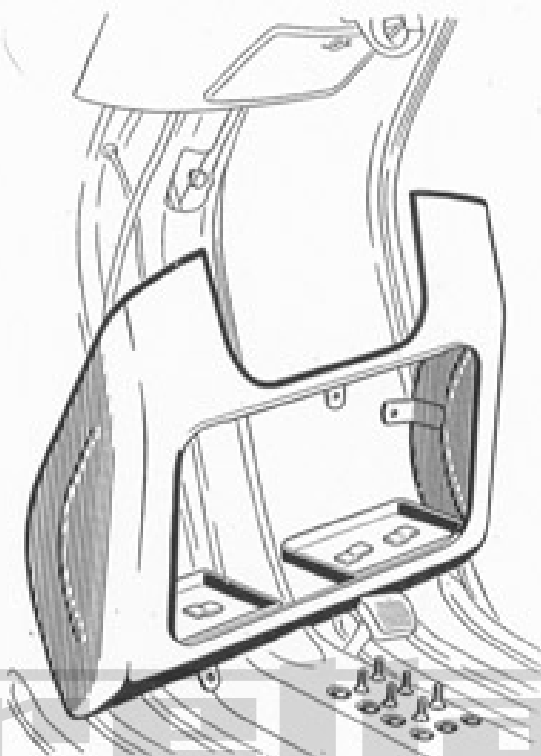

Fig. E 16

Starting, Lighting, and Ignition Switch. Removal and Fitting
(E 18)

1. **Disconnect earth lead.**
Unscrew two countersunk screws and lock washers on the switch. Open the glove locker. Push the switch downwards and remove it. Disconnect all leads and mark them.
2. Replace in the reverse order. **Connect up the earth lead last. Follow the wiring diagram.**

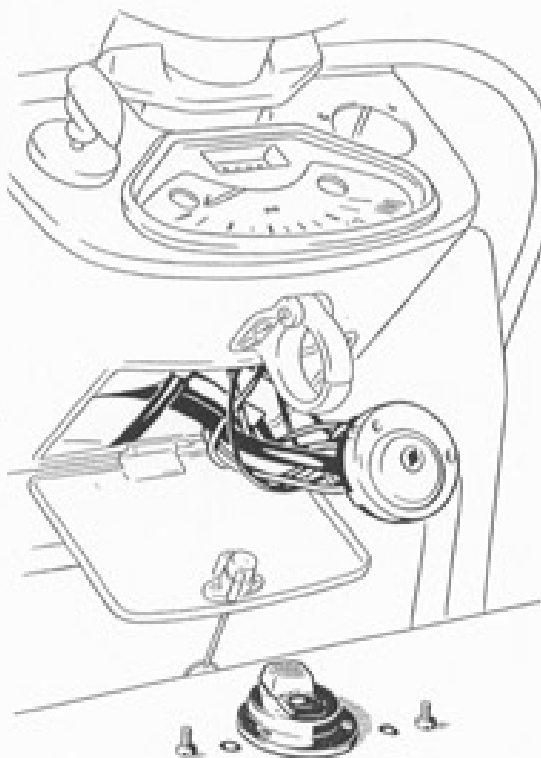

Fig. E 18

Instrument Panel. Removal and Fitting (E 19)

1. Remove the fork cowling (see F 30).
Remove the battery (see E 15).
Remove the battery box (see E 16).
Remove the starting, lighting and ignition switch (see E 18).
2. Unscrew four countersunk screws with star washers on the front of the legshield and take off the instrument panel. It is easiest to remove the speedometer after the instrument panel has been taken off.
3. Replace in the reverse order.

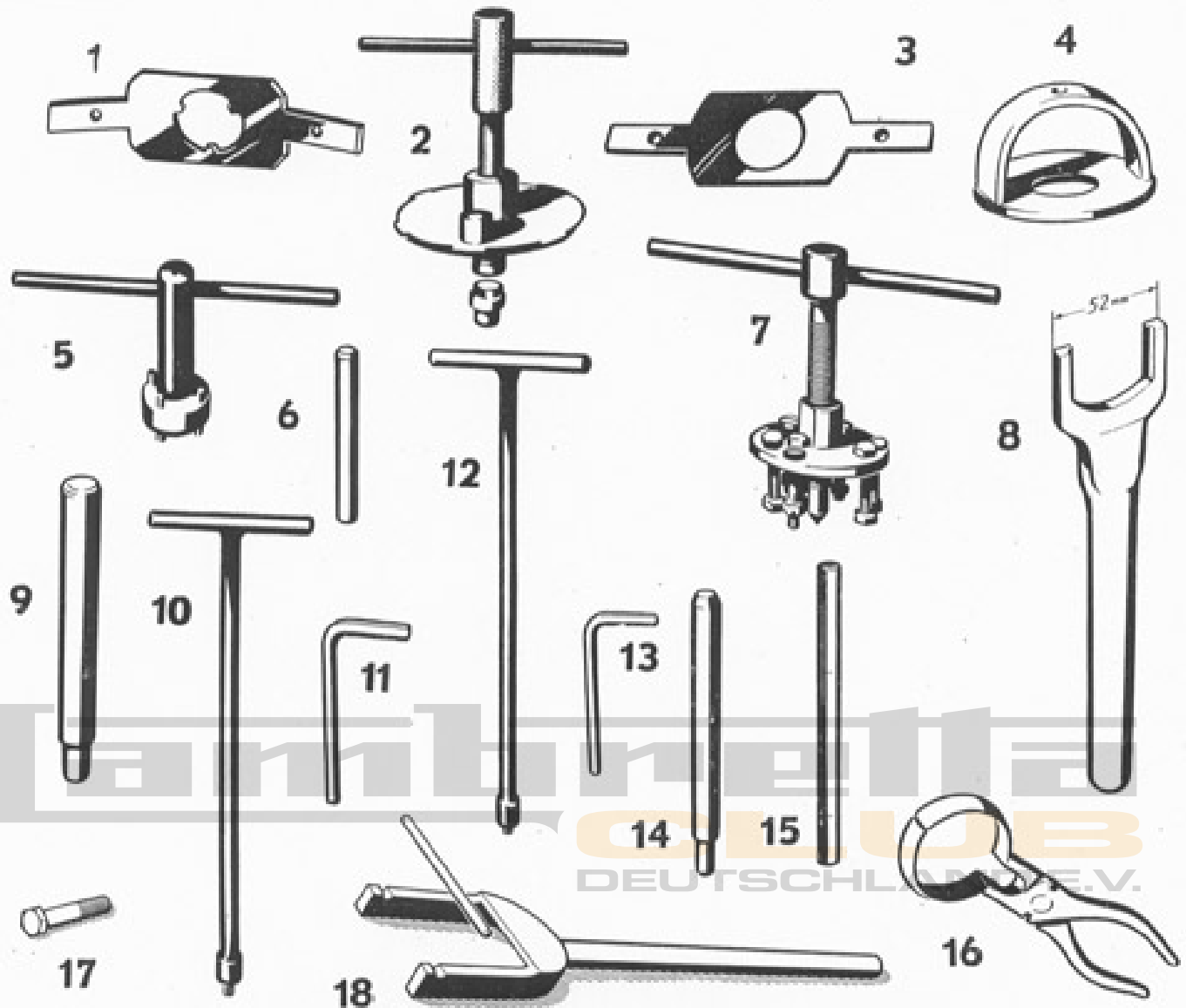
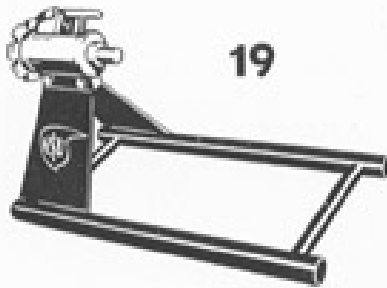
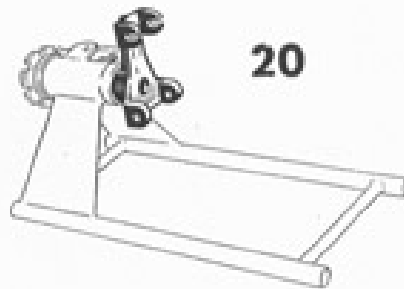

Fig. 1	1 support for clutch hub	11 91 01 108
Fig. 2	1 clutchbell drawer	11 91 01 123
Fig. 3	1 support for clutchbell	11 91 00 130
Fig. 4	1 clutch jig	11 91 02 134
Fig. 5	1 special tool for rear wheel springing	11 91 00 131
Fig. 6	1 punch for removing brake adjuster	11 91 00 921
Fig. 7	1 drawer for brake drum	018 099 743
Fig. 8	1 spanner for upper bearing ring	11 9100 128
Fig. 9	1 punch for fitting distance- and bearing bush	11 91 00 920
Fig. 10	1 socket spanner 5 mm (0.197") for housing screws	11 91 00 111
Fig. 11	1 Allen key 5 mm (0.197") for housing screws	11 91 00 604
Fig. 12	1 socket spanner 6 mm (0.236") for housing screws	11 91 00 124
Fig. 13	1 Allen key 6 mm (0.236") for housing screws	11 91 00 603
Fig. 14	1 mandrel for gudgeon pin	11 91 00 919
Fig. 15	1 punch for checking connecting rod	048 422 014
Fig. 16	1 piston ring compressor	11 91 01 922
Fig. 17	1 extractor bolt	11 91 00 934
Fig. 18	1 assembling tool	11 91 00 935



19



20

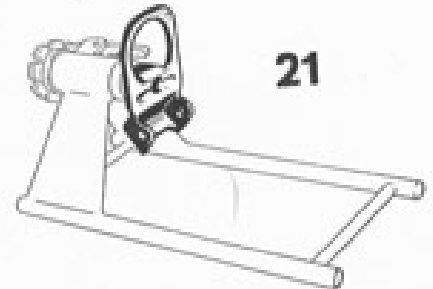

21



22

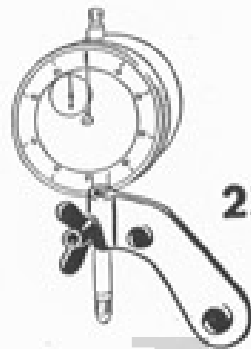

23

Lambretta
CLUB
DEUTSCHLAND E.V.

Fig. 19	1 stand	048 422 000
Fig. 20	1 fixture for holding engine	11 91 01 917
Fig. 21	1 fixture for rear wheel drive	11 91 00 916
Fig. 22	1 punch for removing (split) clutch ballrace	11 91 00 924
Fig. 23	1 bracket for dial gauge	11 91 00 912

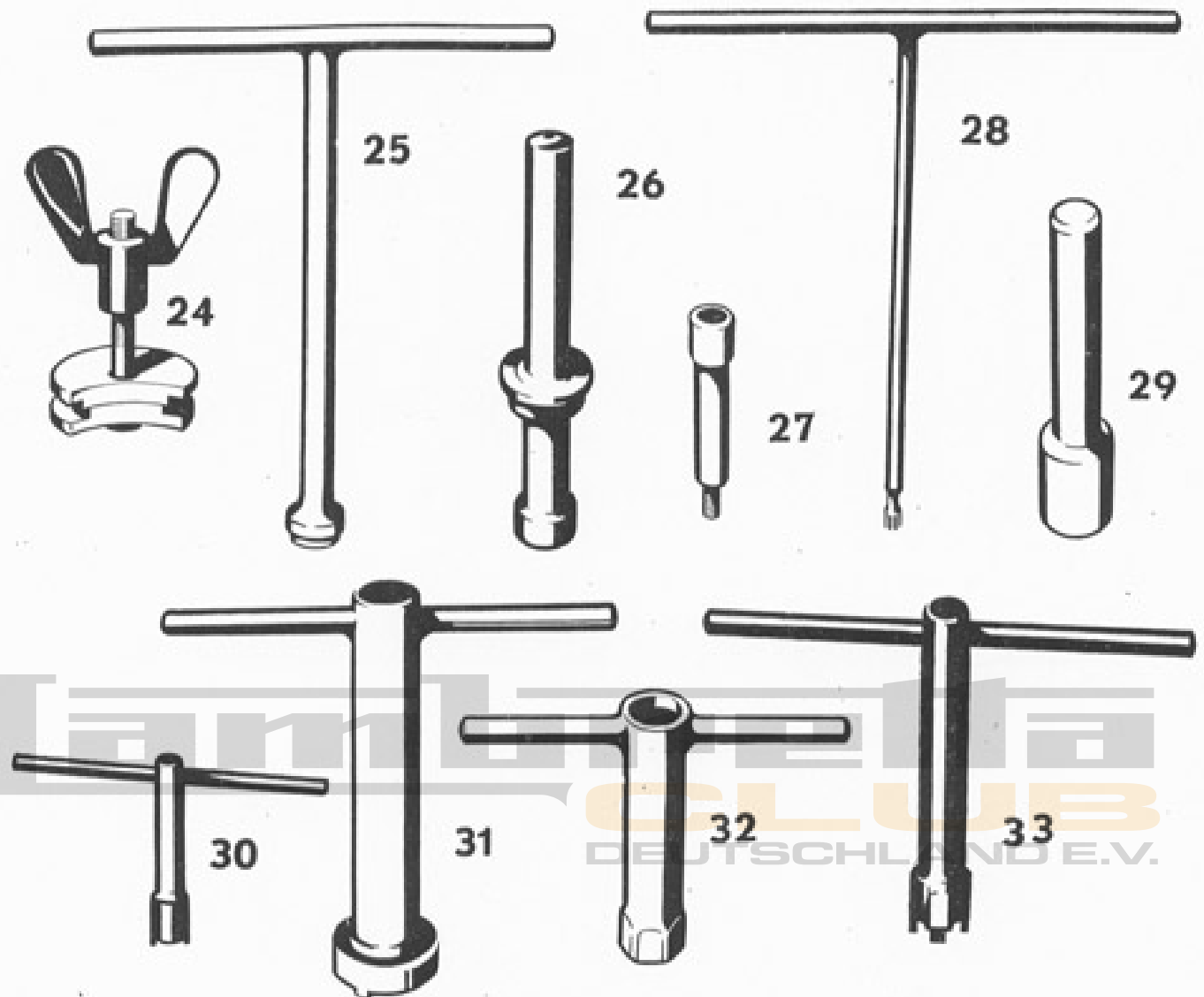

Fig. 24	1 suspension fitting tool	11 91 00 122
Fig. 25	1 socket spanner for magneto flywheel nut	11 91 00 110
Fig. 26	1 punch for knocking in ball bearing (bevel pinion)	11 91 00 908
Fig. 27	1 drawer for bevel pinion	11 91 00 129
Fig. 28	1 holding tool for bevel pinion	11 91 00 903
Fig. 29	1 punch for fitting bevel pinion gasket	11 91 00 918
Fig. 30	1 spanner	11 91 00 133
Fig. 31	1 socket spanner for outer suspension screwed joint.	078 791 905
Fig. 32	1 box spanner 24 mm (15/16") for bevel pinion nut	11 91 00 904
Fig. 33	1 spanner for inner screws	11 91 00 909



SERVICE

FLAT RATE TIMES FOR REPAIR TASKS (Chassis)

NSU PRIMA 150 cc
Standard Times / Page 1
Edition VIII, 1956

Wheels, Brakes, and Forks

F 01	Remove and fit front wheel
F 02	Remove and fit rear wheel
F 03	Remove and fit ball bearing and seal in hub
F 04	Remove and fit front brake back plate
F 05	Remove and fit rear hub
F 08	Renew brake linings (each brake). Strip and assemble brake
F 09	Remove and fit speedometer drive
F 20	Remove and fit front forks
F 21	Remove and fit bearing shells, races, and balls
F 22	Remove and fit front fork springs
F 24	Remove and fit pivoted links (left-hand and right-hand)
F 25	Replace bushes in pivoted links
F 26	Remove and fit front mudguard
F 27	Remove and fit bumper
F 30	Remove and fit fork cowling

Time for task (hrs)	Additional work required	Total time (hrs)
Temps unitaire (heures)	Travaux supplémentaires nécessaires	Temps total (heures)
Tijd (uur)	Benodigde extra werkzaamheden	Totaaltijd (uur)
¼	—	¼
¼	—	¼
¼	F 01, F 04	¾
¼	F 01	½
¼	F 02	½
½	F 01, F 04 or F 02, F 05	1
½	M 52, F 02, F 05	2
¾	F 01	1
½	F 01, F 20, F 30	1¾
¼	F 01	½
	F 01, F 22	¾
¾	F 01, F 24	1¼
¼	F 01, F 20	1¼
¼	—	¼
¼	E 13	½
	F 51, F 53, F 50, F 54 E 13, E 09	¾
¼	F 46, F 40, E 10	1
¼	—	¼
1 ¼	F 83, F 30, E 16, E 19	2 ¾
¼	—	¼
¼	—	¼
¼	—	¼
¼	—	¼
¼	F 45	½
½	E 13, F 30	1
½	E 13, F 30	1
¾	—	¾
¼	F 48, F 45, F 30	1
1	F 46, F 30	1½
½	E 13, F 30	1
	M 01, F 01, F 20, F 21, E 13, F 30, F 46, F 50, F 51, F 52, F 54, F 55, F 71, F 72, E 09, F 61, F 90, F 80, F 63, E 19, E 15, E 16	14
¼	F 71, F 72,	¾
¼	F 02	½
½	F 61, E 09, F 71, F 72	1 ¾
¼	—	¼

Controls and Bowden Cables

F 40	Remove and fit handlebars (with fittings)
F 41	Remove and fit handlebar bend
F 42	Remove and fit speedometer
F 43	Remove and fit speedometer drive shaft
F 44	Remove and fit control levers
F 45	Remove and fit throttle twistgrip
F 46	Remove and fit gearchange twistgrip
F 47	Remove and fit twistgrip or dummy grip sleeve
F 48	Remove and fit slider in twistgrip
F 50	Remove and fit clutch cable
F 51	Remove and fit front brake cable
F 52	Remove and fit cable for gearchange locking mechanism
F 53	Remove and fit throttle cable
F 54	Remove and fit gearchange cable
F 55	Remove and fit cable for strangler and for operating tickler

Frame

F 60	Remove and fit frame
F 61	Remove and fit front central section of panelling
F 62	Remove and fit reard mudguard
F 63	Remove and fit rear central section of panelling
F 65	Remove and fit rear shock absorber



**FLAT RATE TIMES
FOR REPAIR TASKS
(Chassis)**

NSU PRIMA 150 cc
Standard Times / Page 2
Edition VIII. 1956

	Time for task (hrs)	Additional work required	Total time (hrs)
	Temps unitaire (heures)	Travaux supplémentaires nécessaires	Temps total (heures)
	Tijd (uur)	Benodigde extra werkzaamheden	Totaaltijd (uur)
F 67 Remove and fit rear springing	¼	F 02, F 05	1¼
F 68 Remove and fit bearing pin and bush	¼	F 02, F 05, F 67	1½
F 70 Remove and fit exhaust system	½	—	½
F 71 Remove and fit pillion saddle	¼	—	¼
F 72 Remove and fit saddle	¼	—	¼
F 73 Remove and fit prop stand	¼	—	¼
F 74 Remove and fit central stand (and return spring)	½	—	½
F 76 Remove and fit tool box	¼	—	¼
F 80 Remove and fit fuel tank	¼	F 76	¾
F 82 Remove and fit fuel tap and filter	¼	—	¼
F 83 Remove and fit legshield edge strips, left-hand and right-hand	¼	—	¼
F 90 Remove and fit legshield	1¼	F 30, E 15, E 14, E 19, F 83	2¾
F 91 Remove and fit footrests, left-hand and right-hand	½	—	½
Electrical Installation			
E 01 Horn lead	} Remove and fit cable harness	F 30, E 18	2¼
E 02 Rear-light lead			
E 03 Battery lead			
E 04 Lighting lead			
E 05 Remove and fit dip-switch lead	¼	E 10, E 13	¾
E 06 Remove and fit horn	¼	E 13	¾
E 07 Remove and fit fuel gauge tank unit	¼	—	¼
E 09 Remove and fit reflector and rear light	¼	—	¼
E 10 Remove and fit dip switch	¼	—	¼
E 12 Remove and fit headlamp glass and reflector	¼	E 13	½
E 13 Remove and fit headlamp	¼	—	¼
E 14 Remove and fit stop light switch	¼	—	¼
E 15 Remove and fit one battery	½	—	½
E 16 Remove and fit battery box	¼	E 15	¾
E 18 Remove and fit starting, lighting, and ignition switch	¾	—	¾
E 19 Remove and fit instrument panel	¼	F 30, E 15, E 14, E 18, F 42	2

CLUB
DEUTSCHLAND E.V.



S E R V I C E

Dear NSU-Dealer,

Please bear the following points in mind when using this Maintenance Manual:

1. Unless otherwise stated, all instructions refer to both **125 cc** and **150 cc** machines, but only the latter is available.
2. To avoid misunderstandings the illustrations in the spare parts list should be consulted.
3. All nuts and bolts have **right-hand** threads, unless otherwise stated.
4. To carry out this work properly, it is essential that our **Special Tools** are available and used.
5. Only **genuine NSU Spare-Parts and Exchange Units** are to be used as replacements.
6. The **Flat Rate Repairs Times** may be used when preparing estimates and invoices, as well as checking time taken over repairs.
7. Abbreviations are used for the various types of repairs, e. g.

or	Removal and Replacement of Engine	= M 01
	Dismantling and Reassembly of Engine	= M 02

The abbreviations, used in conjunction with the list of Flat Rate Repair Times, should greatly simplify the preparations of job cards.

Yours faithfully,
NSU WERKE AKTIENGESELLSCHAFT



SERVICE APRÈS-VENTE

Cher Agent NSU,

Lorsque vous vous servirez de ce manuel de réparations, nous vous prions de bien vouloir observer les points suivants:

1. Toutes les indications, non accompagnées d'une note particulière, sont valables aussi bien pour les modèles 125 cm³ que pour les modèles 150 cm³.
2. Pour plus de clarté, nous vous recommandons de vous référer aux figures de la liste des pièces de rechange.
3. **Sauf indications spéciales, tous les filetages sont à droite.**
4. L'exécution correcte des travaux suppose que vous soyez en possession de l'**outillage spécial** que nous avons étudié, et que vous l'utilisez.
5. Lors d'un remplacement partiel, il faut utiliser exclusivement des **pièces détachées ou d'échange standard, d'origine.**
6. **Les temps de base** vous serviront à établir les devis de réparations, les factures et à surveiller les temps passés aux différentes opérations.
7. Nous avons adopté des **symboles** pour les divers travaux de réparation, par exemple:

Dépose et mise en place du moteur = M 01

Démontage et montage du moteur = M 02

Ces symboles doivent vous permettre d'abrégé la rédaction des bons de réparation etc., en tenant compte des temps de base.

Sincères salutations

NSU WERKE AKTIENGESELLSCHAFT

Neckarsulm, XII. 1955
1ère Edition



SERVICE

Geachte NSU-dealer!

Bij toepassing van de reparatievoorschriften verzoeken wij U de volgende punten in acht te nemen:

1. Alle aanwijzingen zonder speciale verwijzing gelden zowel voor de 125 cc - uitvoeringen, als ook voor de 150 cc - uitvoeringen.
2. Ter betere oriëntatie wordt aanbevolen de gespecificeerde afbeeldingen van de onderdelenlijst te raadplegen.
3. Voor zover bij schroeven en moeren **geen** bijzondere opmerkingen gemaakt zijn, betreft het steeds **rechtse schroefdraad.**
4. Een vakkundige uitvoering der werkzaamheden stelt in de eerste plaats het aanwezig zijn resp. het gebruik van het door ons ontwikkelde **speciale gereedschap** als voorwaarde.
5. Bij het vervangen van onderdelen dienen uitsluitend **originele onderdelen** resp. **originele ruildelen** gebruikt te worden.
6. **De richttijden der werkzaamheden** dienen voor het opmaken van kostentaxaties en rekeningen, en ter controle van de voor het uitvoeren der reparaties gebruikte tijd.
7. Voor de afzonderlijke reparatie-werkzaamheden zijn **verkorte aanduidingen** aangebracht, zoals b. v.:

Uit- en inbouw van de motor = M 01

of demontage en montage = M 02

Deze verkorte aanduidingen moeten in verbinding met de richttijdenlijst het uitschrijven van reparatie-opdrachten enz. verkorten.

Met vriendelijke groet

NSU WERKE AKTIENGESELLSCHAFT

Neckarsulm, XII. 1955
1. editie



TECHNICAL DATA

125 cc with Kick Starter
(Flywheel Magneto Generator)

125 cc with Electric Starter
(Flywheel Dynamo Starter)

150 cc PRIMA with Electric Starter
(Flywheel Dynamo Starter)

IGNITION

Type of ignition	— Flywheel Magneto Generator 6 volt A. C.	Coil ignition, 12 volt D. C.
Ignition timing	— 5/32" B. T. D. C.	5/32" B. T. D. C.
Contact Breaker Gap	— 0.008" — 0.012" (0.2 — 0.3 mm)	0.016" automatic advance and retard mechanism fully advanced
Type of spark plug	— Bosch W 225 T 11	Bosch W 240 T 11
Spark plug gap	— 0.016" — 0.020"	0.028"

CLUTCH

Clutch	— Multi-plate in oil bath	Multi-plate in oil bath
Clutch operation	— By hand	By hand
Clutch spring pressure	— 119 lb	119 lb
Clutch adjustment	— 3/16" — 5/8" play between clutch cover and lever	3/16" — 5/8" play between clutch cover and lever

TRANSMISSION

Gearbox	— NSU 3-speed gearbox	NSU 3-speed gearbox
Oil level in gearbox	— For Initial Filling: approx. 0.57 pt. engine oil SAE 30 (or gearoil SAE 80). For oil changes: approx. 0.35 pt.	For Initial Filling: approx. 0.57 pt. engine oil SAE 30 (or gearoil SAE 80). For oil changes: approx. 0.35 pt.
Filling with grease of rear wheel drive casing and suspension	— Appr. 10 1/2 oz. Epix or pressure lubrication grease (Remove both filler plugs and apply pressure grease gun to the filler on the suspension until grease oozes out of the opening of the drive casing.)	Appr. 10 1/2 oz. Epix or pressure lubrication grease (Remove both filler plugs and apply pressure grease gun to the filler on the suspension until grease oozes out of the opening of the driving casing.)
Type of engagement	— Driving pin	Driving pin
Axial float of the gear shafts	— 0.008" (not to be compensated)	0.008" (not to be compensated)
Drive, Engine-Gearbox	— Straight or spiral bevel gears	Spiral bevel gears
Drive, Gearbox-Rearwheel	— Shaft drive, straight or spiral bevel gears and spur gears with straight teeth	Shaft drive with spiral bevel gears and spur gears with straight teeth



SERVICE

TECHNICAL DATA

NSU-SCOOTER 125/150 cc
Technical Data / Page 3
Edition XII, 1955

125 cc with Kick Starter

(Flywheel Magneto Generator)

Ratio, Engine-Gearbox	1.31 : 1
Ratio of gears	
1st gear	2.7 : 1
2nd gear	1.46 : 1
3rd gear	1 : 1
Ratio, Gearbox-Rearwheel	3.76 : 1
1st gear	13.45 : 1
2nd gear	7.24 : 1
3rd gear	4.93 : 1

125 cc with Electric Starter

(Flywheel Dynamo Starter)

Ratio, Engine-Gearbox	1.31 : 1
Ratio of gears	
1st gear	2.7 : 1
2nd gear	1.46 : 1
3rd gear	1 : 1
Ratio, Gearbox-Rearwheel	3.76 : 1
1st gear	13.45 : 1
2nd gear	7.24 : 1
3rd gear	4.93 : 1

150 cc PRIMA with Electric Starter

(Flywheel Dynamo Starter)

Ratio, Engine-Gearbox	1.3125 : 1
Ratio of gears	
1st gear	2.96 : 1
2nd gear	1.46 : 1
3rd gear	1 : 1
Ratio, Gearbox-Rearwheel	3.77 : 1
1st gear	14.66 : 1
2nd gear	7.259 : 1
3rd gear	4.948 : 1

TRANSMISSION

WHEELS and BRAKES

Road wheels	Removable
Tyre size	400 x 8
Inflation pressure	
Front Wheel	10 — 11.5 lb. sq. in.
Rear Wheel	18.5 lb. sq. in. solo, 25 lb. sq. in. with pillion passenger
Type of rim	2.45 — 8 DIN 7824 well base
Maximum road speed	Appr. 46.6 m. p. h.
Front wheel brake	Internal brake shoes mechanically operated
Rear wheel brake	Internal brake shoes mechanically operated
Brake operation	Front: hand operated Rear: foot operated
Average retardation	Front wheel: 3.1 m/sec ² Rear wheel: 4.0 m/sec ²

Road wheels	Removable
Tyre size	400 x 8
Inflation pressure	
Front Wheel	10 — 11.5 lb. sq. in.
Rear Wheel	18.5 lb. sq. in. solo, 25 lb. sq. in. with pillion passenger
Type of rim	2.45 — 8 DIN 7824 well base
Maximum road speed	Appr. 46.6 m. p. h.
Front wheel brake	Internal brake shoes mechanically operated
Rear wheel brake	Internal brake shoes mechanically operated
Brake operation	Front: hand operated Rear: foot operated
Average retardation	Front wheel: 3.1 m/sec ² Rear wheel: 4.0 m/sec ²

Road wheels	Removable
Tyre size	400 x 8
Inflation pressure	
Front Wheel	10 — 11.5 lb. sq. in.
Rear Wheel	18.5 lb. sq. in. solo, 25 lb. sq. in. with pillion passenger
Type of rim	2.45 — 8 DIN 7824 well base
Maximum road speed	Appr. 50 m. p. h.
Front wheel brake	Internal brake shoes mechanically operated
Rear wheel brake	Internal brake shoes mechanically operated
Brake operation	Front: hand operated Rear: foot operated
Average retardation	Front wheel: 4.17 m/sec ² Rear wheel: 4.0 m/sec ²

MISCELLANEOUS DATA

Wheel base	48.4" (1230 mm)
Total length	71.3" (1810 mm)
Overall width	29" (738 mm)
Overall height	38.4" (975 mm)
Ground clearance	4.7" (120 mm)
Height of saddle	31.1" (790 mm)

Wheel base	49.6" (1259 mm)
Total length	72.2" (1834 mm)
Overall width	29" (738 mm)
Overall height	38.8" (986 mm)
Ground clearance	5.3" (135 mm)
Height of saddle	30.8" (781 mm)

Wheel base	49.6" (1259 mm)
Total length	72.2" (1834 mm)
Overall width	29" (738 mm)
Overall height	38.8" (986 mm)
Ground clearance	5.3" (135 mm)
Height of saddle	30.8" (781 mm)



SERVICE

TECHNICAL DATA

NSU-SCOOTER 125/150 cc
Technical Data / Page 4
Edition XII. 1955

125 cc with Kick Starter
(Flywheel Magneto Generator)

125 cc with Electric Starter
(Flywheel Dynamo Starter)

150 cc PRIMA with Electric Starter
(Flywheel Dynamo Starter)

- Frame — Central steel tube with sectioned strengthening pieces
- Front fork — Swinging fork
- Rear wheel springing — Swinging fork
- Stand — Centre stand
- Unloaded weight with fuel — 220 lbs (100 kg)
- Permissible total load — 595 lbs (270 kg)
- Fuel capacity — 1 gallon 3 1/4 pints (6.3 ltr.) (including 2 1/4 pints (1.2 ltr.) reserve)

- Central steel tube with sectioned strengthening pieces
- Swinging fork
- Swinging fork, hydraulically damped
- Centre stand and prop stand
- 264 lbs (120 kg)
- 595 lbs (270 kg)
- 1 gallon 3 1/4 pints (6.3 ltr.) (including 2 1/4 pints (1.2 ltr.) reserve)

- Central steel tube with sectioned strengthening pieces
- Swinging fork
- Swinging fork, hydraulically damped
- Centre stand and prop stand
- 270 1/2 lbs (123 kg)
- 630 lbs (295 kg)
- 1 gallon 5 pints (7.3 ltr.) (including 2 1/4 pints (1.2 ltr.) reserve)

MISCELLANEOUS DATA

EQUIPMENT

- Electrical equipment — Flywheel magneto generator 6 volt, with battery, head-lamp and electric horn
- Instruments — Illuminated speedometer and clock
- Accessories — Safety hook for parcels, adjustable handle-bars and driver's saddle, pillion seat and spare wheel, steering safety lock, tools.

- Flywheel dynamo starter with contact breaker LA 12/45/60, 2 batteries, head- and parking-lamp, electric horn
- Illuminated speedometer and clock, clock with external winder. Starting-lighting, ignition-switch, handle for choke and tickler.
- Safety hook for parcels, adjustable handle-bars and driver's saddle, pillion seat and spare wheel, steering safety lock, tools.

- Flywheel dynamo starter with contact breaker LA 12/45/60, 2 batteries, head- and parking-lamp, electric horn
- Illuminated speedometer and clock, clock with external winder. Starting-lighting, ignition-switch, handle for choke and tickler.
- Safety hook for parcels, adjustable handle-bars and driver's saddle, pillion seat and spare wheel, steering safety lock, tools.

Removal and Replacement of Engine (M 01)

Special Tools.

Drawer for removing rotor 018 098 024.

"C" spanner for exhaust pipe nut 128 052 134.

1. Remove both cowlings.
2. Disconnect battery earth lead.
3. Remove left hand and right hand foot rest, after the nuts and one bolt which secure the exhaust have been undone.
4. Remove the exhaust system.
Remove the front silencer securing screw and undo the joint on the cylinder, using "C" spanner 128 052 134. Remove gasket and exhaust system.

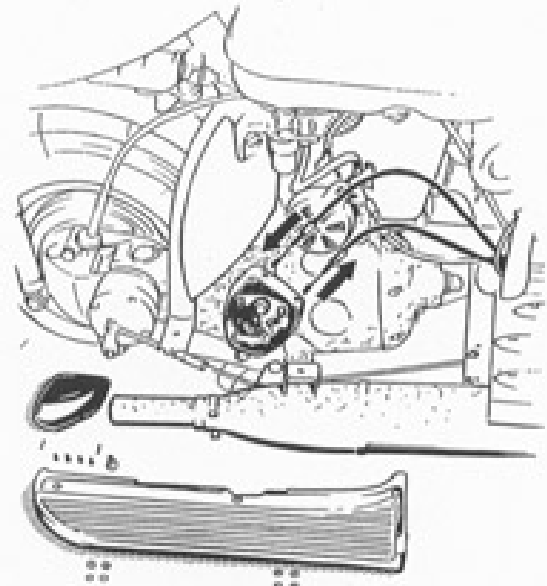

Fig. M 01/8

5. Remove H. T. connector.
6. Withdraw fuel pipe.
7. Remove carburettor, after the clamping screw has been loosened.
8. Removal of operating cable from gearbox.
9. Remove dome nuts and take off rear wheel.
10. Remove rear mudguard, first unscrewing front and rear fixing screws.
11. Remove right and left hand air ducts, after slackening the seven screws.

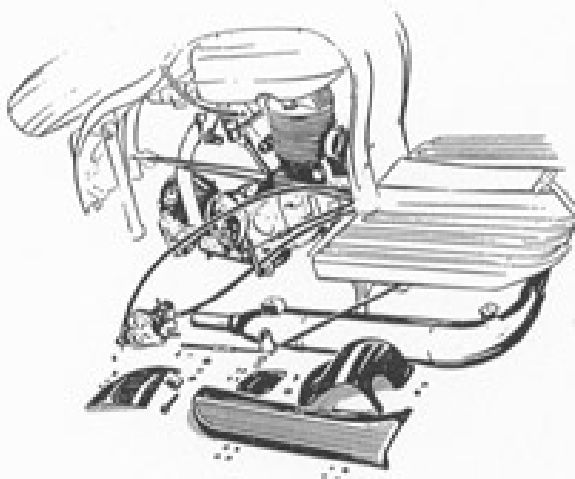

Fig. M 01/3-7

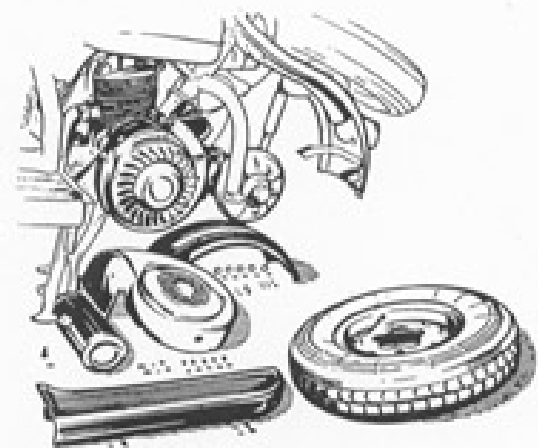

Fig. M 01/10-11

8. Removal of operating cable from gearbox.
Unscrew the gearbox cover and remove it. Remove both split-pins from segment. Screw in cable adjusting screw on gearbox housing and take off nipple. Pull out cable after the adjusting screws have been removed.

12. 125 cc engine with kick starter: withdrawal of rotor.
Remove circlip, take off cover plate undo nut and withdraw rotor with the drawer 018 098 024. Remove upper screw with large washer. Pull out lighting cable, after the grub screw has been loosened. **Mark cable.**

13. 125 cc and 150 cc engine with flywheel dynamo starter:

Remove cables No. 51 and No. 61 from the regulator, cable No. 1 from the ignition coil and the heavy starter cable No. 50 from the generator housing. (See wiring diagram).

14. Undo the clutch operating cable on the engine.

15. Pull out speedometer drive after the securing screw on the suspension has been removed.

16. Undo the shock absorber fixing screw on the suspension.

17. Remove rear brake lever split-pin and take off circlip on the intermediate lever

18. Removal of stand.

Place blocks under frame. Unhook pull-off spring with a screwdriver, loosen screw, and take off stand. Meanwhile, replace the screw with a suitable pin (5/16" Ø) (8 mm Ø).

19. Loosen engine suspension.

125 cc with kickstarter:

Remove the securing screws on the rear engine suspension and on the splash guard.

19a 125 cc and 150 cc engine with flywheel dynamo starter:

Slacken nuts only, as, on this frame, slots are incorporated on both sides of the fixing.

Special note. When undoing the nuts, hold the engine by the swinging link and let it slide down gently, at the same time removing the pin.

During dismantling, be careful about wedge rings.

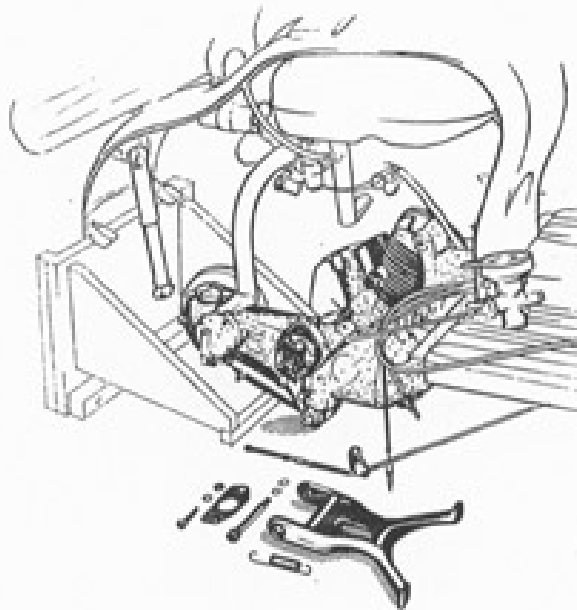

Fig. M 01/14 — 19

20. Engine replacement.

125 cc and 150 cc engine with flywheel dynamo starter:

Wedge rings are to be stuck with grease into the engine fixing holes. These are essential for the alignment of the engine. Slide in engine from below and put pin into the lower hole. Lift up the engine by the swinging link.

20a 125 cc engine with kickstarter:

Insert upper front bolt. (The upper front bolt on the 125 cc and 150 cc engine with flywheel dynamo starter has already been fitted with a wedge ring during assembly of engine). Replace holding plate, spring washer and nut, and place compensating washer (leather) for flange in position. Insert both bolts together with splash guard and tighten slightly. Remove pin.

Centre stand with hooked-in release spring.

(long end towards frame) is to be inserted and fixed to the frame by means of a bolt. Tighten all bolts and make sure that both holding plates are seated correctly.

21. Replace rear wing.

Place wing in position (cable clips point to the left) and secure to engine and chassis.

22. Replacement of exhaust system.

Place gasket in position on cylinder head and screw in pipe. (Use graphite). Attach silencer, secure to leg shield and tighten screwed joint on cylinder with spanner 128 052 134 as well as the clamp bolt on silencer pipe.

DEUTSCHLAND E.V.

23. Replace wires
125 cc and 150 cc engine with flywheel dynamo starter:
See wiring diagram. Attach cables Nos. 51 and 62 to control box, heavy starter cable No. 50 to dynamo housing and cable from engine to ignition coil terminal No. 1. Replace rubber shroud.

23a On the 125 cc engine with A.C. equipment, the cables are replaced with the rotor removed. Be careful about the large washer on the stator.

24. Refit air ducts
Place left-hand air duct on generator housing and tighten up. Place right-hand air duct on to the inlet connection of the cylinder, and screw on to the left-hand duct.

25. Refit carburettor
Place carburettor in position, tighten clamp screw, making sure that the carburettor is in a vertical position. Fix operating cable on fuel tank. Replace fuel pipe.

26. Replace gearbox operating cable and adjust gear-change mechanism.
Ensure correct fitting of the cables on the handlebar. Engage 1st gear; screw the shorter end of one cable into the front hole of the gear casing on the engine. Replace the nipple of the pull-wire and pin up. Fit second cable in the same manner. Engage 2nd gear and take up all play by means of the adjuster. Lock adjusters with lock nuts. Test for correct adjustment by engaging all the gears. Grease sector well. Place paper gasket in position and refit cover.

27. Replace speedometer drive.
Pass speedometer drive through suspension with a little grease and tighten fixing screw. Replace rubber shroud.

28. Re-hang shock absorber and tighten with screw.

29. Replace brake rods.
Replace intermediate lever (bell crank) on pivot and secure with washer and circlip. Adjust brake by means of the adjuster on the rear brake rod (3/4" — 1 3/16" play at foot-brake pedal).

30. Replace clutch operating cable.
Take up excessive play by means of the adjuster fitted with lock nuts.

31. Refit foot-rests.
Replace foot-rests and tighten with nuts and spring washers. Secure silencer with setscrew on right-hand foot-rest.

32. Fill gearbox with oil or check oil level.
(See lubrication chart)
If the oil has been drained, remove filler plug on the engine and fill with appr. 1/3 pint of SAE 30 oil. When the machine stands on level ground and with the filler plug on the clutch cover removed, the oil should drip from the level plug.

33. Replace rear wheel.
Place rear wheel on brake drum and secure with spring washers and dome nuts.

34. Refit left and right hand cowling and lock.

35. Run engine and road test, adjust carburettor with the engine hot.

32. Fill gearbox with oil or check oil level.

Checking oil

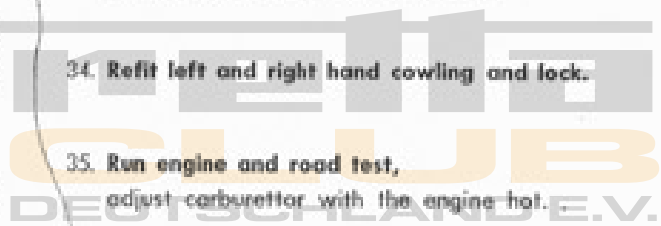

Dismantling of Engine after Removal (M 02)

Special tools required:

see illustrated on page "Special tools".

1. Remove rear wheel drive together with suspension.

(This can also be done in the frame).

Secure engine to the engine stand (11 91 00 917). Remove oil filler and drain-plugs and drain oil. **Engage third gear.** Remove circlip from the left-hand side of the pin, and drive out pin. Loosen all socket-head screws on the flange

of the drive housing with an Allen key and take them out with the two special socket spanners (11 91 00 111 and 11 91 00 124). Hold the toothed segment, to prevent the rollers of the third gear from falling out.

2. Remove cylinder head.

(This can also be done in the frame, after the tank has been removed).

Unscrew sparking plug. Remove 4 nuts and washer, lift out cylinder head.

If 150 cc engine is fitted, mind the gasket between head and barrel.

3. Remove cylinder barrel and gasket

(this can also be done in the frame).

Remove cylinder barrel and gasket, cover with rag. Mark piston.

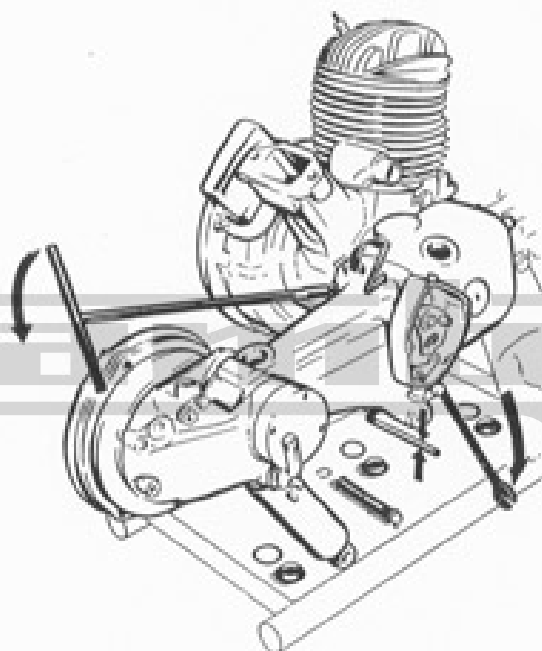

Fig. M 02/1

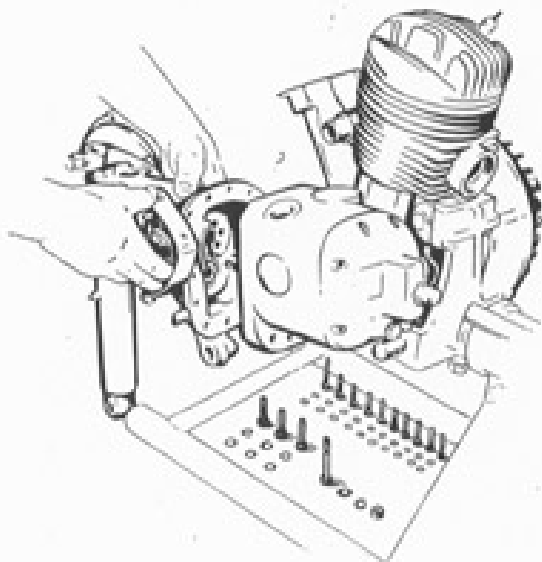

Fig. M 02/1a

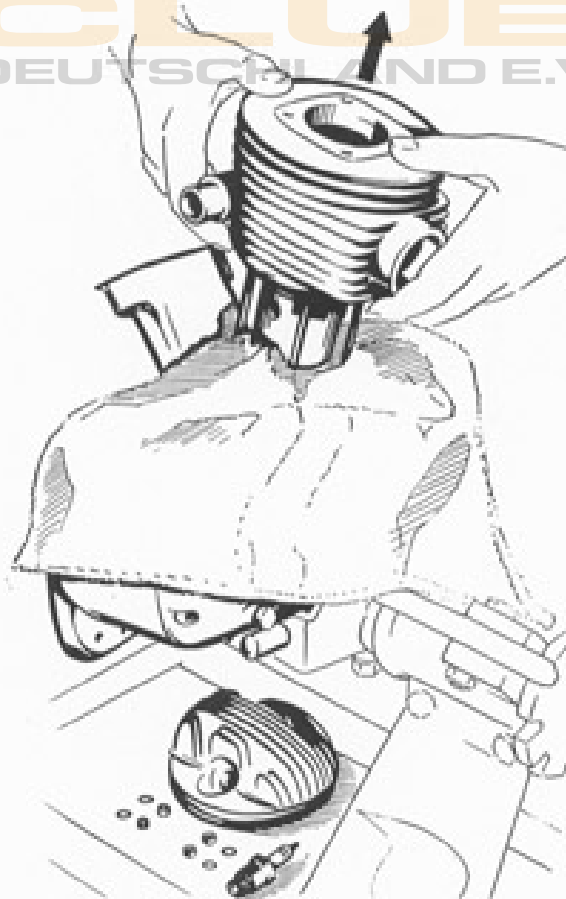

Fig. M 02/3

Prima
CLUB
DEUTSCHLAND E.V.

Take off 2 gudgeon pin circlips. Heat up piston and press out gudgeon pin with a drift (11 91 00 919).

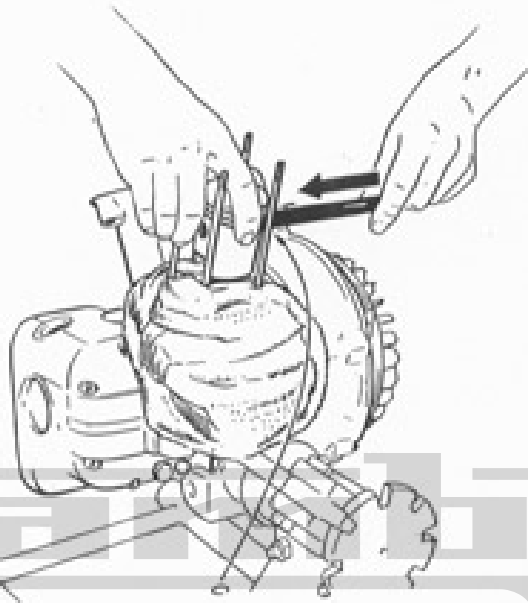

Fig. M 02/3a

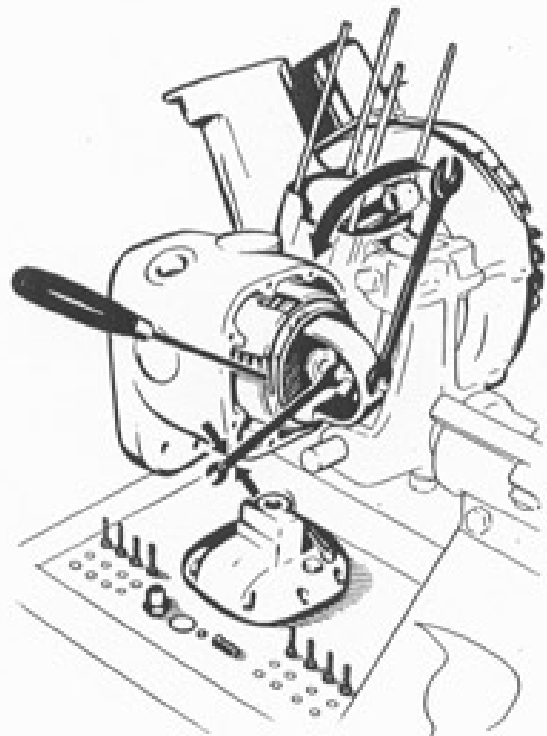

Fig. M 02/5

Remove tensioner and take off all plates. Place special tool (11 91 01 108) on clutch hub. Bend back tab washer and remove both.

DEUTSCHLAND E.V.

4. Remove kick starter.

(This can also be done in the frame).

Remove crank lever. Remove all nuts and bolts on the starter housing cover, take off cover and washer. Unscrew 2 screws on the inside of the starter housing (turn starter shaft slightly) and take off kick starter completely.

5. Remove clutch.

(This can also be done in the frame).

Unscrew the cap on the clutch cover, remove gasket. Remove the 2 nuts from the operating rod and take off bush together with ballhead.

Remove all screws on the clutch cover, using special socket spanner (11 91 01 108). Take off cover and gasket. Place tensioner (11 91 02 134) on the operating rod, and tighten with a nut until the clutch springs are sufficiently compressed to free the securing ring. Take off securing ring with a small screw-driver.



Fig. M 02/5a

Remove clutch hub and spring washer. Take off main shaft. Bend back lock washer of the bell housing, insert tool (11 91 00 130) undo nut with box spanner (11 91 00 904), take off lock washer.

Insert mandrel (part of tool 11 91 01 123) into gunmetal bush of the drive shaft, place drawer

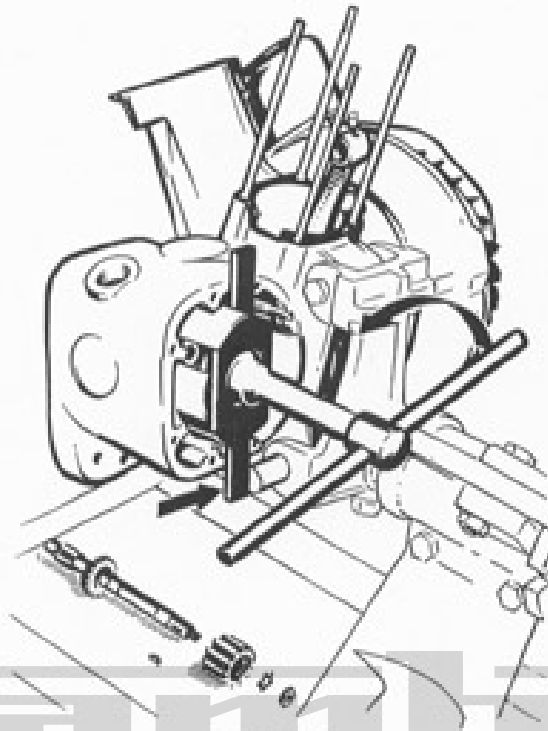

Fig. M 02/5b

into the clutch housing, and withdraw with the spindle.

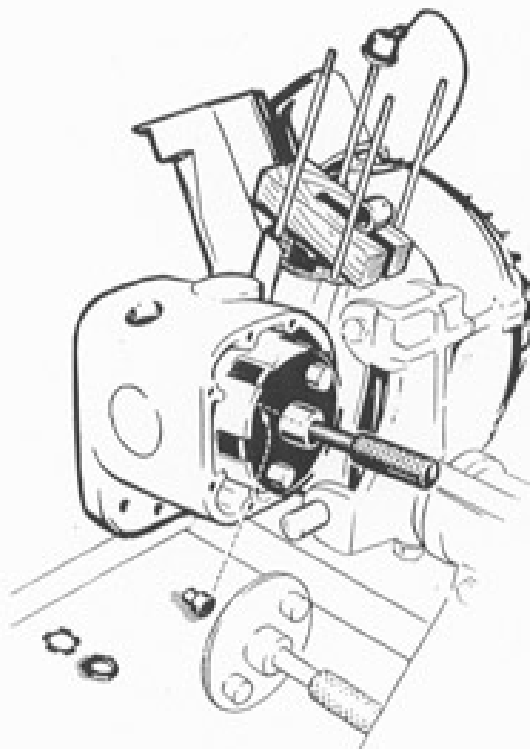

Fig. M 02/5c

6. Remove drive shaft.

Remove countersunk screws from the ball race flange, take off flange, cover housing with rag, and knock out ball race with drift (11 91 00 924).

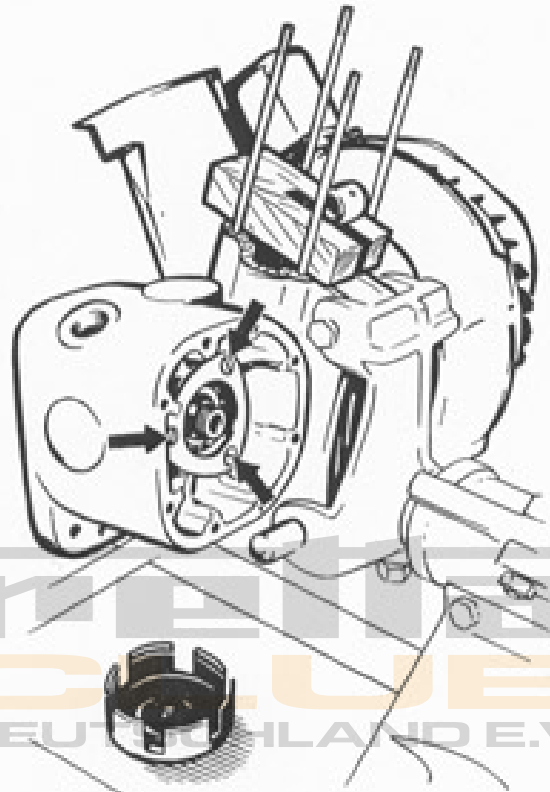

Fig. M 02/6

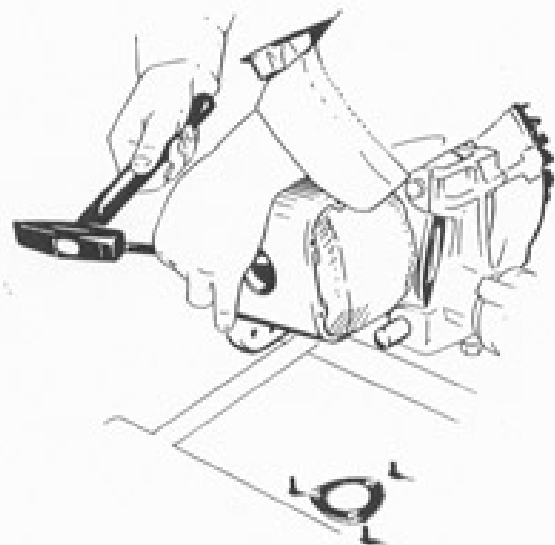

Fig. M 02/6a

Take off drive shaft and shims and tie together.

7. Remove flywheel magneto generator.

(This can also be done in the frame)

Remove circlip with screwdriver, take off cover. Support connecting rod with a slotted piece of wood. Undo rotor nut, take off spring washer, and draw off rotor with drawer (018 098 024). Unscrew the screws on the stator as well as those on the terminal plate, take off stator and Woodruff key.

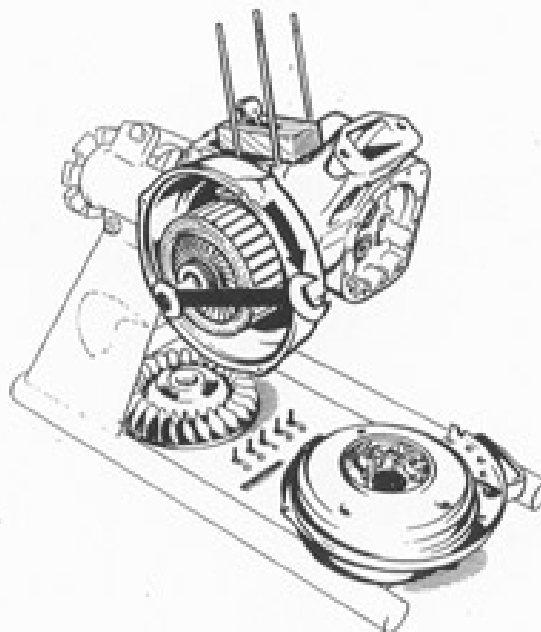

Fig. M 02/7b

7a Remove flywheel generator starter.

(This can also be done in the frame).

Remove circlip with screwdriver, take off cover, undo bolt, and take off fan. If necessary, insert a pin, 6 mm \varnothing (1/4"), 70 mm long (2 3/4") into the shaft, and withdraw with 1 screw M 10, appr. length of thread 40 mm (1 9/16").

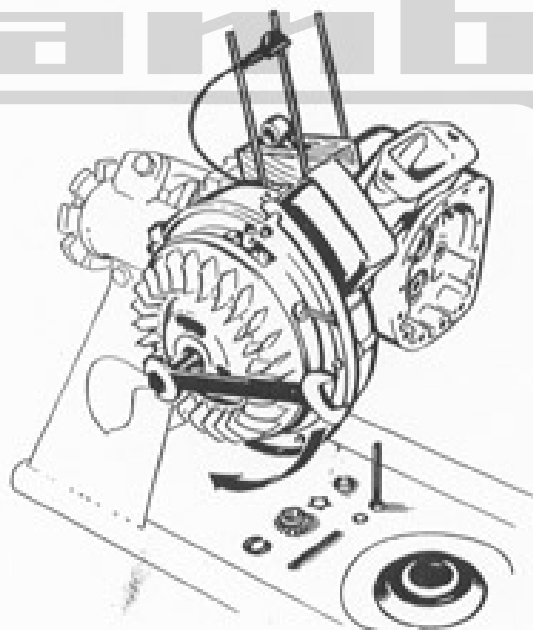

Fig. M 02/7a

8. Removal of crankshaft, 125 cc engine.

Bend back tab washer on the left hand shaft nut. (On engines with flywheel dynamo starter, remove flange or knock out lockplate from the drive end side by means of a hammer and drift).

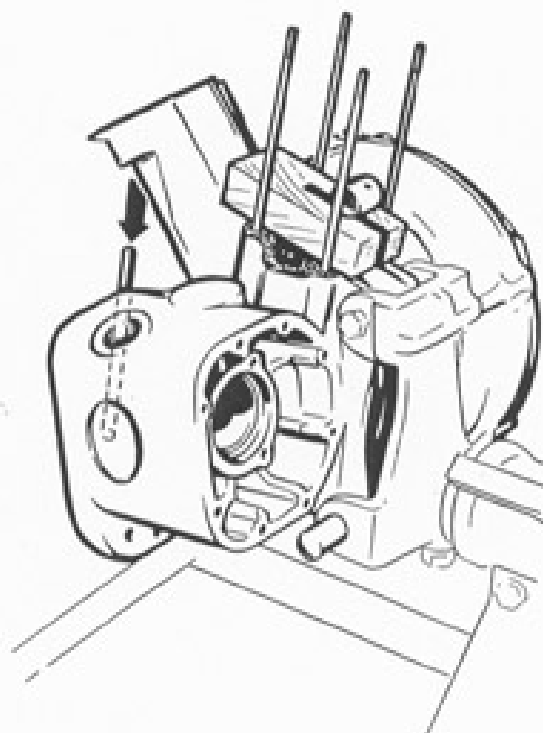

Fig. M 02/8

Remove 5 screws and spring washers on the dynamo housing. Raise both brushes and take off housing complete. Insert a pin 6 mm \varnothing (1/4") 40 mm long (1 9/16") into the armature shaft, and withdraw with the bolt.

Unscrew nut (left hand thread) and take off together with the lock washer.

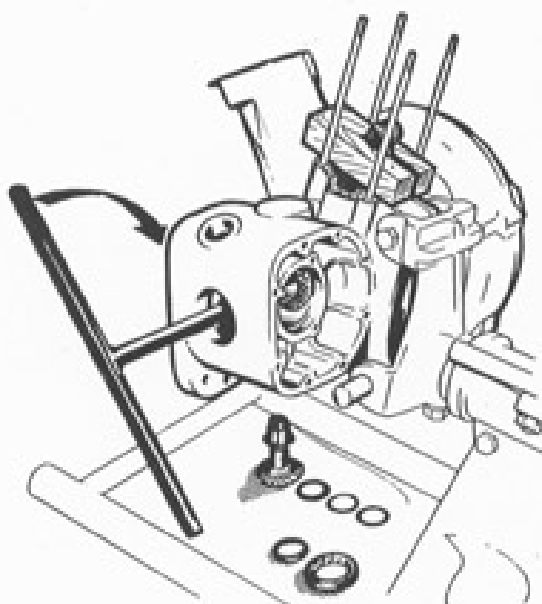

Fig. M 02/8a

Take off spring washer on the left hand shaft. Remove screws on the bearing cover. Loosen bearing cover by knocking gently with rubber mallet. Unscrew the bolts on the left hand side of the crank with socket spanner (11 91 00 115).

Take off crankshaft half (dynamo end) together with shim, mark connecting rod and remove, as well as the needles (27 in number) and shim.

Carefully knock out the crankshaft half (drive end) with a brass drift.

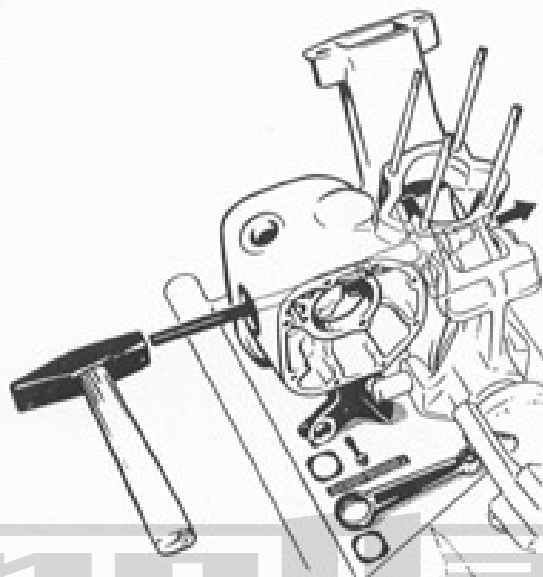

Fig. M 02/8c

Take off bevel gear and shims and tie together.

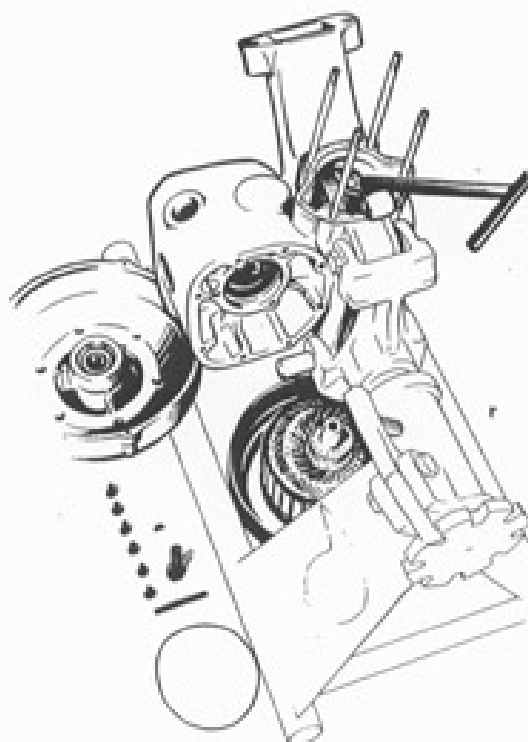

Fig. M 02/8b

8a Removal of crankshaft, 150 cc engine.

This is exactly the same as for the 125 cc engine, up to and including the removal of the bearing cover.

Turn crankshaft to **B. D. C.** and knock out, gently hitting right-hand shaft with brass drift and hammer; note slot in the housing. Remove bevel gear as well as shims and tie together.

9. Renewal of bearing in crankcase.

On 125 and 150 cc engines with flywheel dynamo starter, the flange must be taken off first. Heat up crankcase evenly. Remove bearing. The ballraces will fall out when the crankcase has been knocked against a wooden board.

10. Clean engine parts, inspect them, and exchange defective parts.

Clean carefully all engine parts, inspect them, and renew faulty ones.

Reassembly of Engine (M 02)

11. Refitting crankshaft on 125 cc engine. (Crankshaft does not require balancing)

Fix crankshaft housing on the stand. Slide crankshaft half (drive end) into the housing. Fit washer on crank pin, and replace big end (note the marking) together with 27 needles. Oil well. Place washer on crank pin.

Special note. Do not oil the protruding part of the crank pin or the bore of the left crankshaft half. Slide in crankshaft (dynamo end).

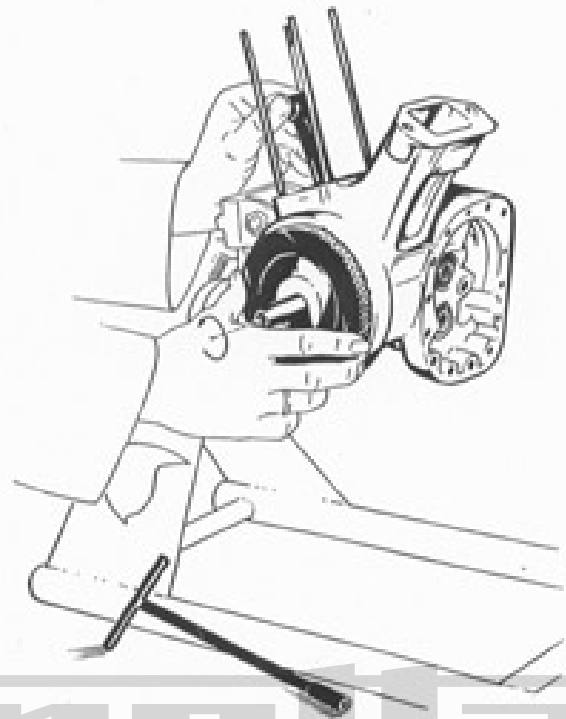

Fig. M 02/11a

flats is parallel to the cheek. Otherwise the bolt head will catch on the crankcase.

DEUTSCHLAND E.V.

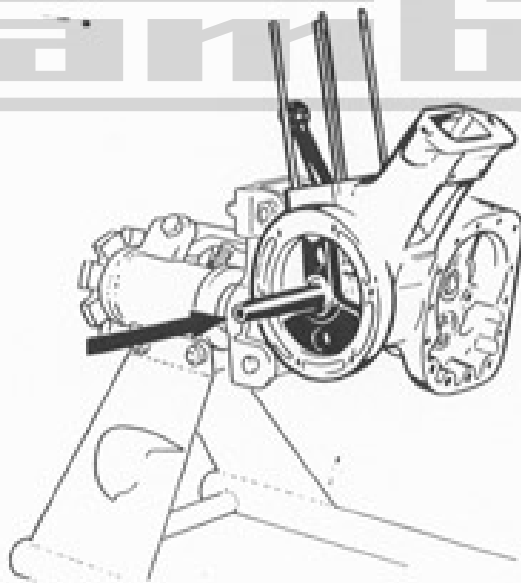

Fig. M 02/11

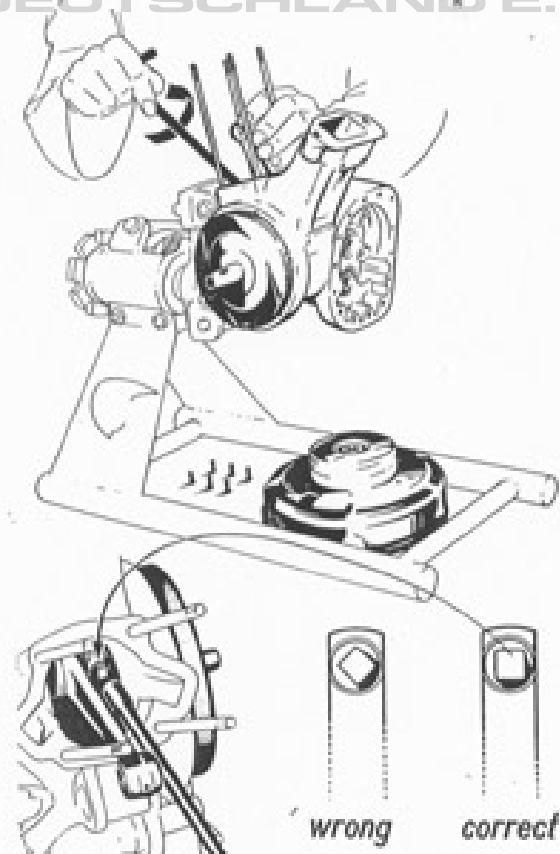

Fig. M 02/11b

Screw in crankpin securing bolt, but do not tighten. Attach centring tool, (11 91 00 900). Turn crankshaft, as this centres it. Tighten securing bolt firmly in such a manner that one of the

Test the crankshaft for true running with a dial gauge (adjust if necessary). Caulk securing screw with centre punch. Remove centring tool. Oil all moving parts. Place gasket on bearing cover. Apply sealing compound to the crankcase and surface of cover. Replace cover, tighten up, and ensure that the cast-in slot of the cover points to the flange on the crankcase. Tighten bolts crosswise.

11a Refitting crankshaft on 150 cc engine:
(Crankshaft not to be equalised).

Place complete crankshaft into position so that the crank pin is at bottom dead centre. (Note the slot on the casing). Oil all moving parts. Replace crankcase gasket with gasket cement. Fit bearing cover. (Note locating bush in the bearing cover). Replace washer and tighten crosswise with nuts.

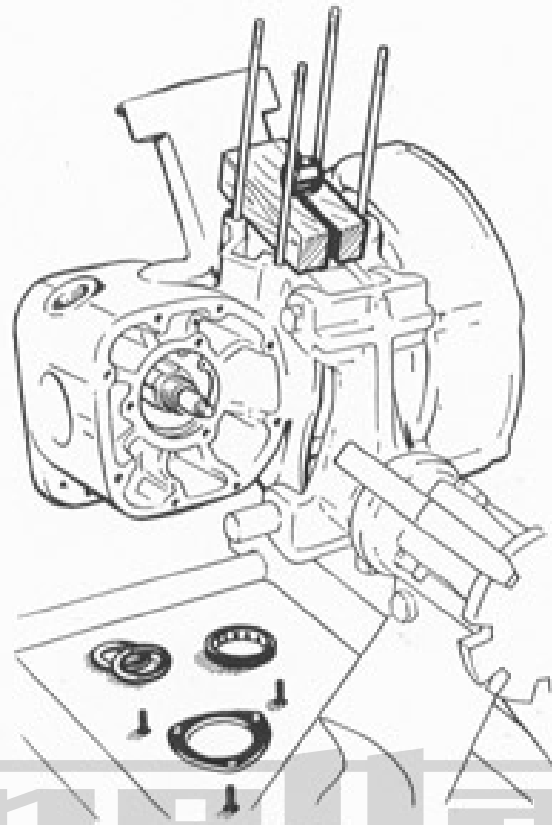

Fig. M 02/12

NSU CLUB
DEUTSCHLAND E.V.

12. Refit bevel gear set, checking backlash and meshing.

Each pair of gears has been lapped on the engine and can, therefore, only be fitted in pairs.

Both wheels are always marked with the same number. The lapping mark can be observed on the profile of the tooth. **When checking the meshing, the gears must be free from oil and grease.** Place previously removed shims on the right hand shaft of the crankshaft. Put bevel pinion in position (do not knock on). Wedge small end with wood block. Fit lock washer. Press on bevel pinion and nut (left hand thread) and secure. (Do not tighten nut yet).

Replace drive shaft, (note recess in housing) slide in main shaft and insert shims. Grease the ball race and inner ring well. Knock in gently as far as the circlip on the 125 cc engine, and as far as the housing on the 150 cc engine.

Replace ball bearing flange, which must lie flat on the outer ring of the ball bearing, and secure with 3 countersunk screws. **Tighten screws evenly**, otherwise the drive mainshaft will not run freely and evenly. Screws must only be locked when the pinion meshing has been found to be correct.

Place clutch bell in position together with the pressed-on inner ring of the ballrace, fit lock washer and nut.

Insert tool (11 91 00 130) and tighten securely with box spanner (11 91 00 904). (See Fig. M 02/5b).

Turn clutch bell to make sure that the main shaft is running freely, as the shaft must run evenly in every position. If it does not do so the three screws have not been tightened evenly. Fit dial gauge by means of bracket (11 91 00 912) into one of the clutch bell cut outs. Ascertain the clearance between the teeth by moving the bell up and down; this must be 0.004" - 0.008" (0.10 - 0.20 mm).

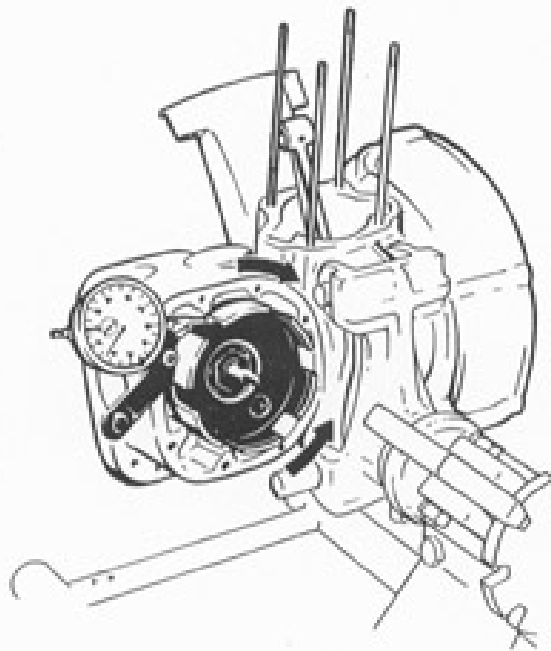

Fig. M 02/12a

Remove dial gauge. Apply a little colouring or thin oilpoint to both flanks of 6—8 teeth of the gear wheel on the drive shaft. Turn the clutch bell and by applying pressure in the opposite direction on the small end, make certain that the gears are meshing tightly. The point mark will show whether the gears mesh correctly.

There will be no point left on the bearing surface of the teeth. If the point marks are incorrect, they will indicate on which of the gears shims must be removed or added.

When the point marks and meshing prove correct, replace the clutch. This work must be carried out with care, as the life of the gear set depends on the accuracy of their adjustment. (See page 12).

13. Replacement of clutch

First remove the clutch bell which has already been fitted, and caulk the 3 countersunk screws on the flange with a centre punch. Secure nut on the right-hand end of the shaft with all tabs of the lock washer. (Insert screwdriver through the crankcase bore). Replace clutch bell, fit nut and lock washer, and fix with tool (11 91 00 130). Lock up nut. Insert spring washer in the main drive shaft and fit clutch hub. Fit nut and lockwasher, tighten up and lock. (Use holder No. 11 91 01 108).

Fit clutch plates, starting with one of the lined ones and alternating these with the remaining

plates. Replace operating rod, outer clutch plate springs, and spring cups by means of the jig. (11 91 00 134). (The turned side of the outer clutch plate must point to the outside).

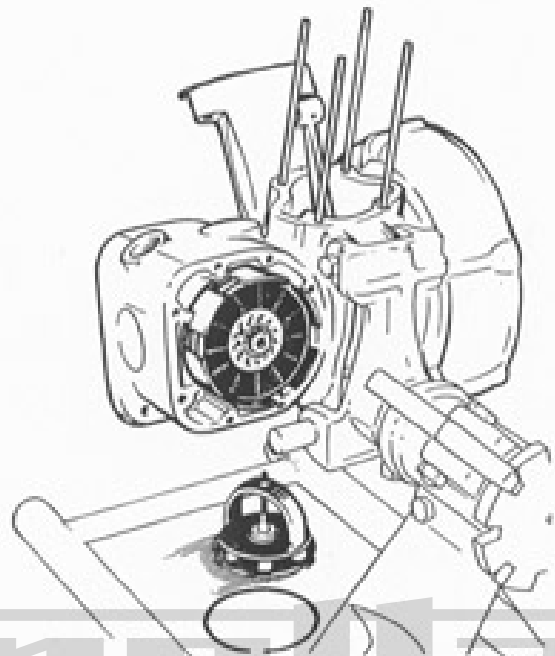

Fig. M 02/13

Fit the spring ring so that its opening is covered by the solid part of the clutch bell. Remove jig. Check correct seating of spring ring.

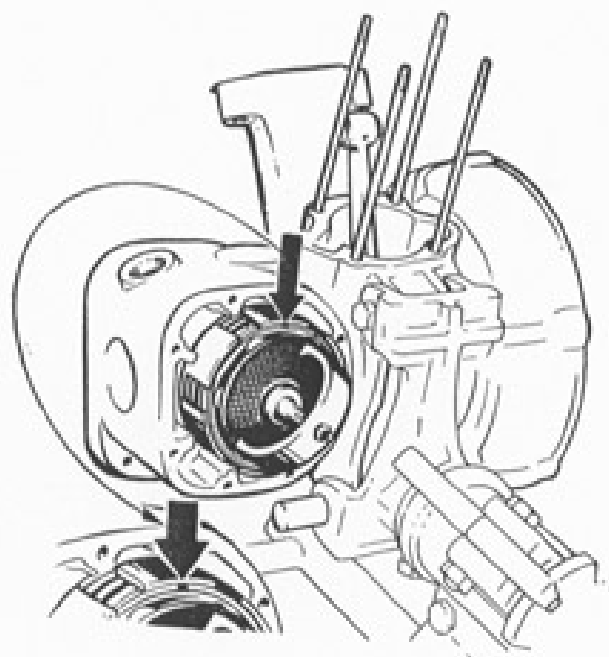

Fig. M 02/13a

General Instructions for Fitting Spiral Bevel Gears

1. **Basic rule:** Always assemble correctly meshed, irrespective of whether the teeth mate over their complete length or not.
2. **Correct meshing:**
 - without load:
 - On the leading flank (v): Bearing surface in the middle;
 - On the trailing flank (r): Bearing surface nearer the outer diameter;
 - Teeth must never be in engagement on the inner diameter.**
3. **Check meshing:** Point the flanks of the gear teeth on one wheel with thin oil point, and turn gears several times in the normal direction of rotation. The point will be squeezed away from the contact area, leaving it bare. Normally the air gap between the teeth must not exceed 0.006"—0.008" (0.16—0.20 mm).

This is how the gears mesh when they are assembled (without load)

This is the effect in service under load.

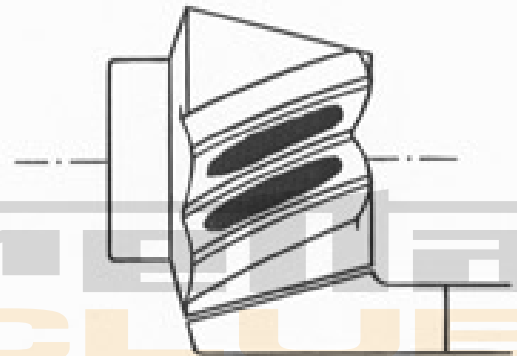
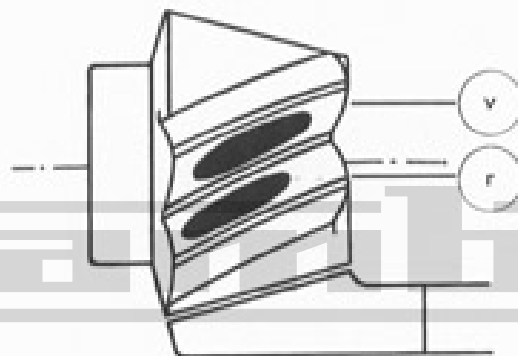

What action must be taken when the bearing surfaces on the gears are as illustrated below?

This is what must be done

The result must be the normal gear engagement (see above).

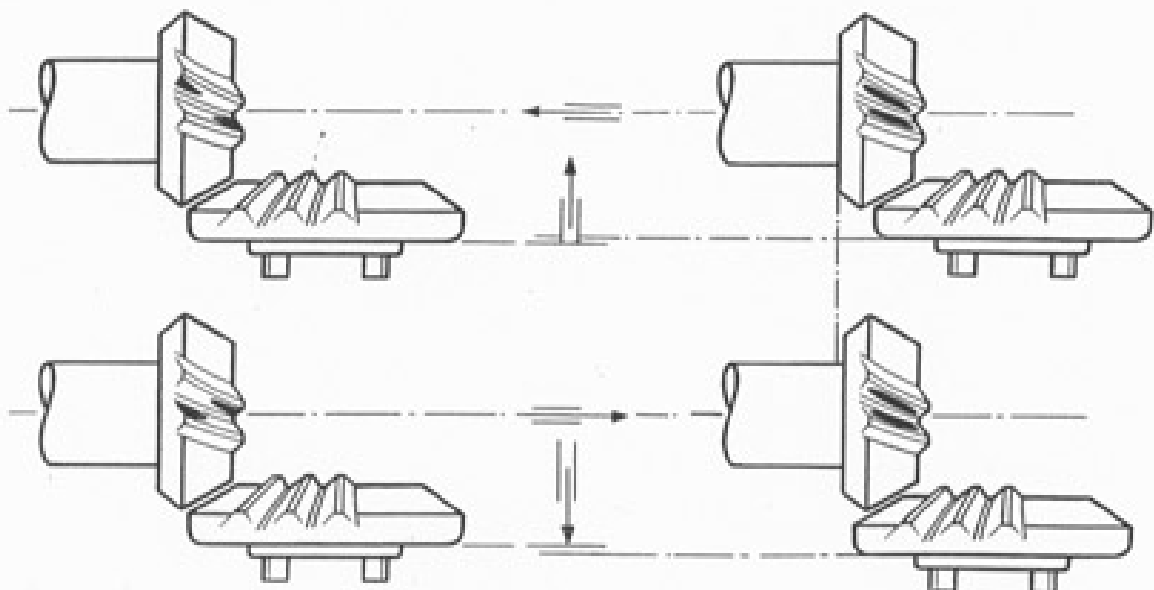

All the above notes refer to the driving bevel gear, when (v) is the leading flank, and (r) is the trailing flank!

Stick gasket with grease to clutch cover and refit cover. Fit bush with ballhead in such a way that the ballhead points to the outside.

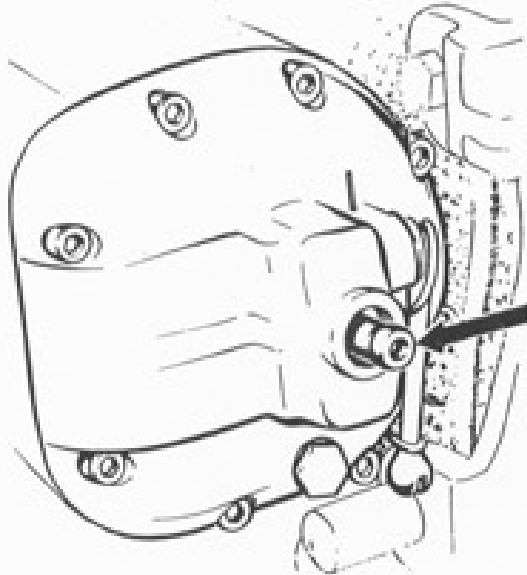

Fig. M 02/13b

Fit nut on operating rod, so that the clutch lever has $3/16'' - 5/16''$ (5-8 mm) play. Put on second nut and lock the two nuts together. Insert cap and washer and tighten.

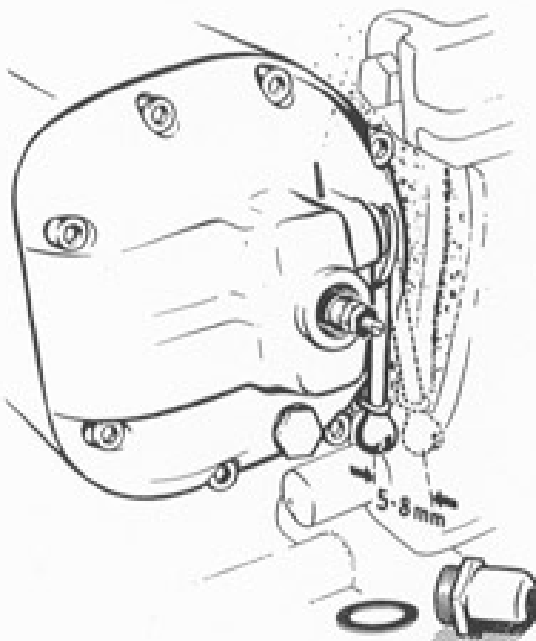

Fig. M 02/13c
5-8 mm = $3/16'' - 5/16''$

14. Flywheel magneto generator. - Replacement on 125 cc engine.

Replace Woodruff key; fit base plate and tighten (note marking). Fit flywheel magneto with fan and washers, and tighten with nut.

14a Flywheel dynamo starter - Replacement on 125 cc and 150 cc engine

Replace Woodruff key and fit armature. The taper must be free from oil and grease. Refit dynamo housing with screws and spring washers so that the control box points to the bracket on the crankcase. Replace brushes. Place wood block under small end, replace fan wheel and tighten with screw and star washer.

15. Lining up connecting rod.

On 125 cc engine, line up connecting rod with drift (11 91 00 923) and on 150 cc engine with drift (048 422 014).

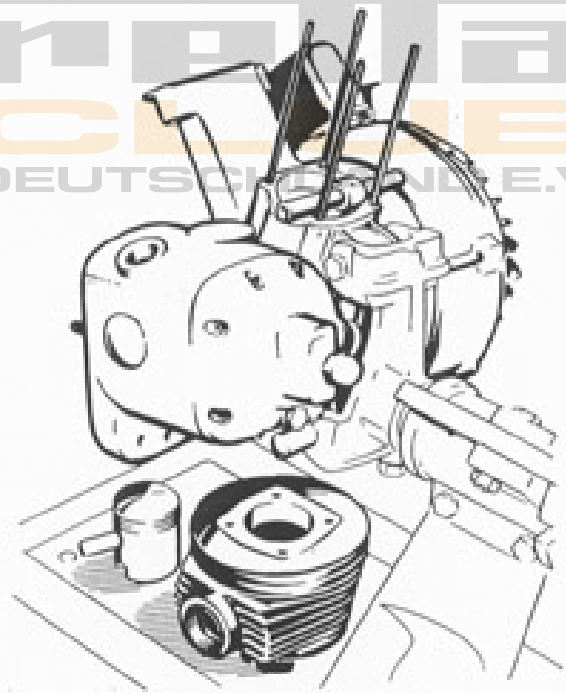

Fig. M 02/15

16. Fitting piston and cylinder block

Place gasket on housing flange. Corners must not protrude into transfer ports. Fit one gudgeon-pin circlip into piston. Cover with rag. Heat up piston (note markings) and press in gudgeon-pin with gudgeon-pin tool (11 91 00 919). Fit second circlip.

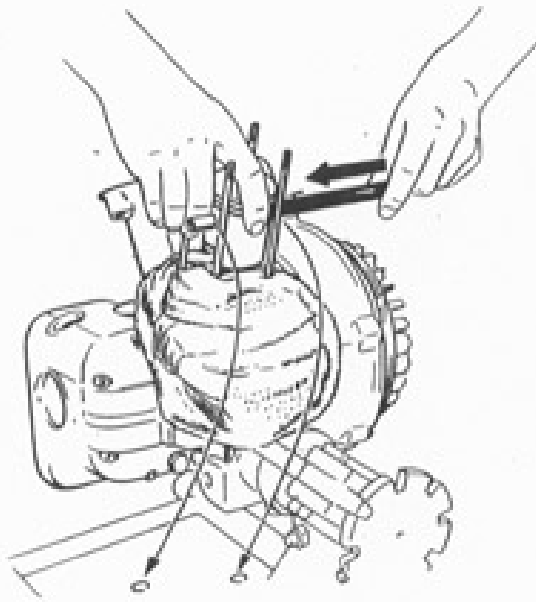

Fig. M 02/16

Check piston rings to see that they are in the correct position and oil the piston well. Replace cylinder block, using piston ring compressor. (11 91 00 922 or 11 91 01 922 respectively).

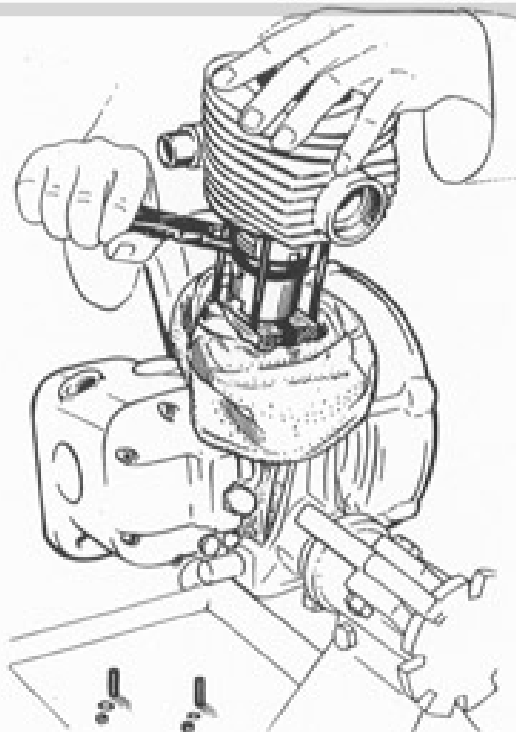

Fig. M 02/16a

17. Set ignition timing.

Flywheel magneto generator on 125 cc engine

Contact gap 0.008" — 0.012" (0.20 — 0.30 mm), 0.16" (4 mm) before T. D. C. (0.189" (4.8 mm) if measured at angle through the plug hole).

17a Flywheel dynamo starter.

125 cc engine: Contact gap 0.016" (0.4 mm), 0.16" before T. D. C. (4 mm) with automatic advance and retard mechanism fully advanced (0.198" if measured at an angle through the plug hole).

17b 150 cc engine: Contact gap 0.016" (0.4 mm), 0.165" — 0.169" (4.2 — 4.3 mm) before T. D. C. with automatic advance and retard mechanism fully advanced (0.232" if measured at an angle of 45° and 0.248" at 30°).

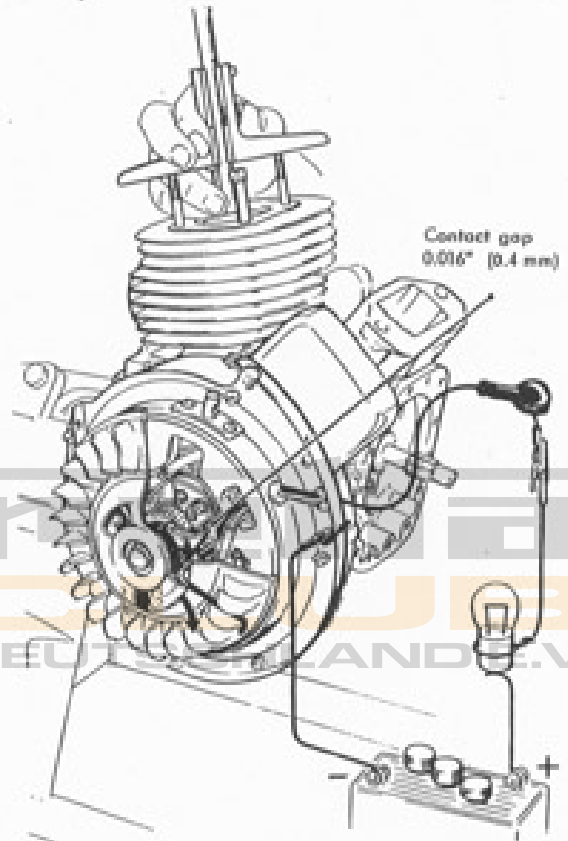
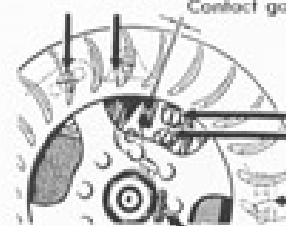

Fig. M 02/17



Contact gap 0.016" (0.4 mm)

Fig. M 02/17a



Contact gap 0.008" — 0.012" (0.2 — 0.3 mm)

Fig. M 02/17b

After the ignition has been timed, replace the cover and fit the spring ring.

**18. Refitting of cylinder head on 125 cc engine**

Refit the cylinder head without gasket, with the plug hole pointing towards the carburettor. Tighten nuts crosswise. Insert sparking plug.

18a Refitting of cylinder head on 150 cc engine

Refit cylinder head together with gasket. Then as for 125 cc engine.

19. Replace oil filler and drain plug with gasket, fit cover disc with packing and secure by tapping with a hammer. Take engine out of stand.

Rear Wheel Transmission and Suspension

20. Removal of transmission.

Secure transmission housing, complete with suspension, on stand (11 91 00 916). Engage second gear and take off sliding wheel, shaft, gear selector fork with countershaft, and top gearwheel. Note needle rollers (24 in number). Take off drive shaft with a pair of pliers.

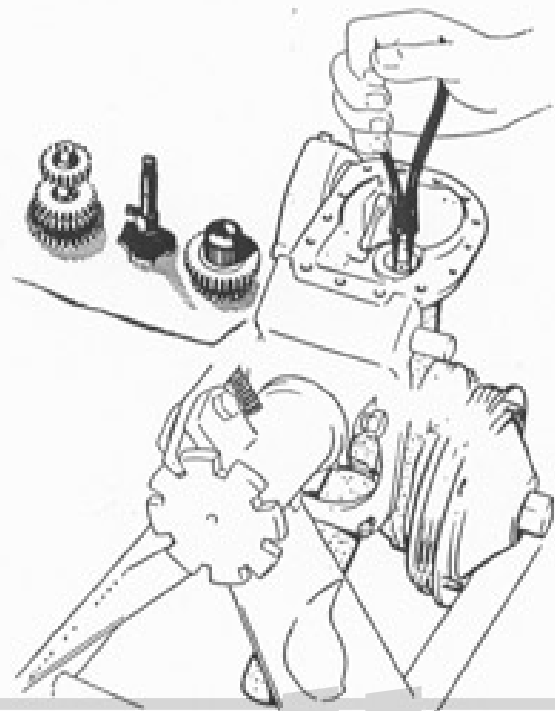

21. Removal of brake drum

Secure suspension to the stand with a socket head bolt. Remove brake drum nut and draw off drum with puller (018 099 743).

Fig. M 02/20

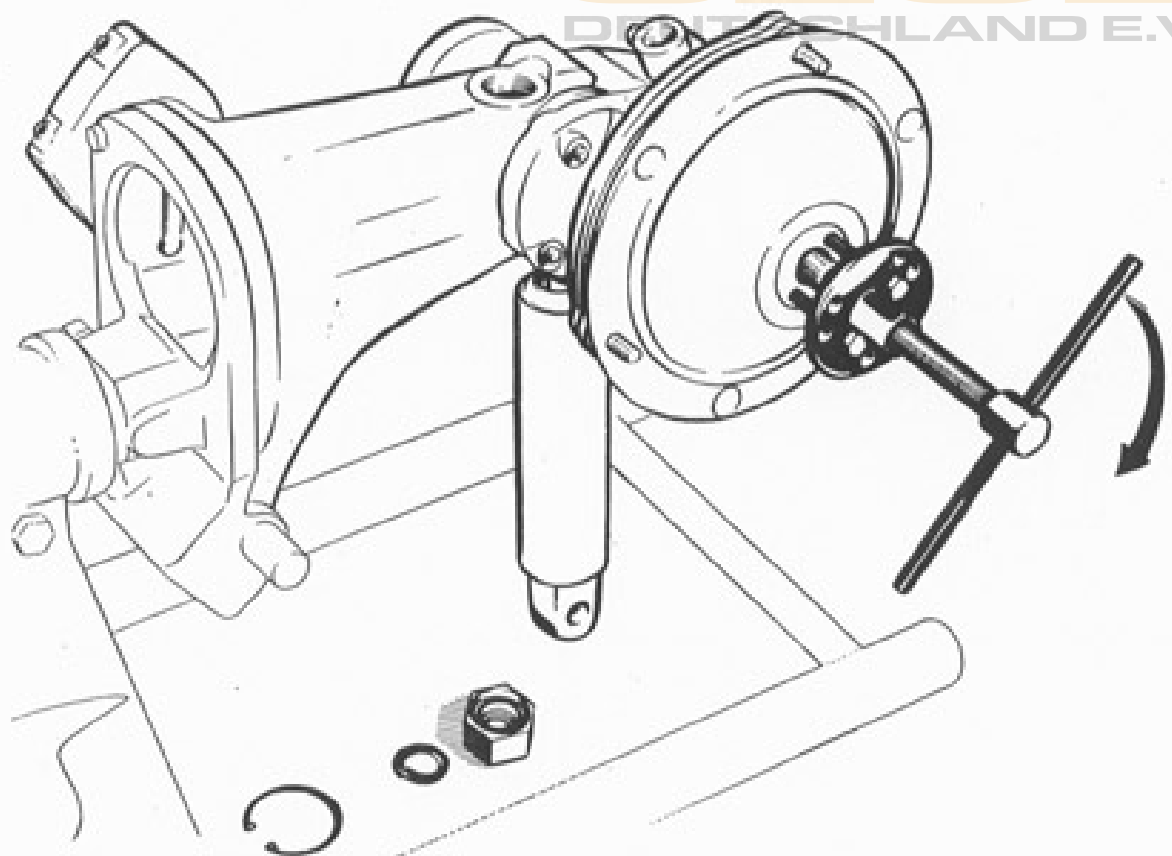

Fig. M 02/21

Lambretta CLUB
DEUTSCHLAND E.V.

22. Removal of brake shoes and rear wheel springing

Mark the position of the brake lever.

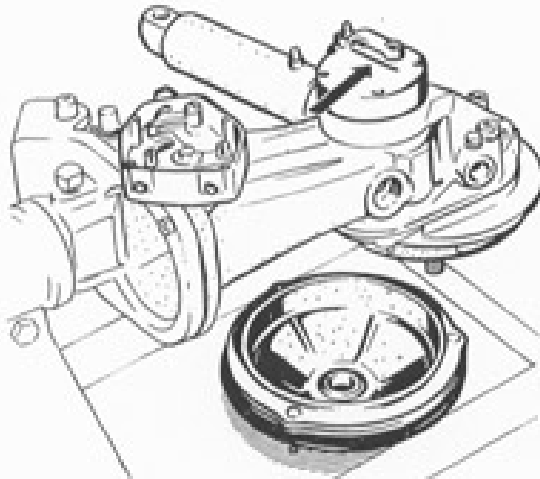

Fig. M 02/22

Remove the circlip which secures the brake shoes to their spindle, take off shoes and pull-off spring. Take off circlip from brake lever. Tap out brake shaft with drift (11 91-00 921). Take off brake lever and lock washer. Unscrew nut and take off spring washer.

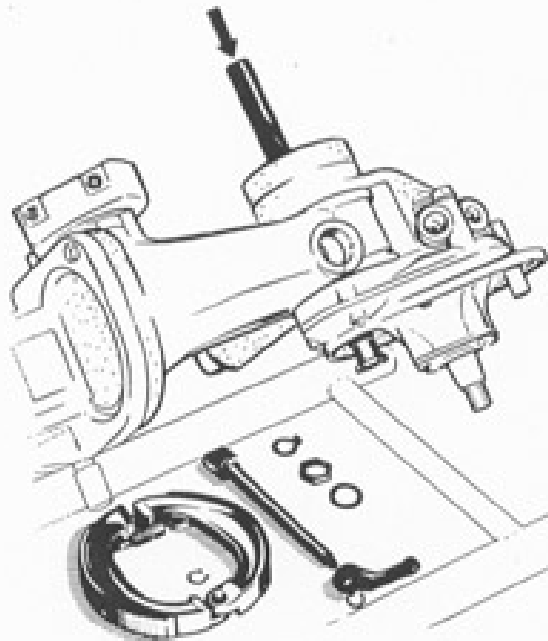

Fig. M 02/22a

Special Note. On the 125 cc engine, turn the drive shaft, so that the large gear wheel is in the position shown in Fig. M 02/22b. If this is not done, the bearing bush will be damaged causing grease to escape.



Fig. M 02/22b

Tap out bearing bush and packing ring, using tool (11 91 00 920). Take off rear wheel springing.

23. Removal of gear casing.

(Only if the rear wheel drive has to be changed). Unscrew bolt and take off together with gearchange segments. Remove the three countersunk screws, together with the cone shaped star washers. Take off gear casing, together with pressure spring and protection plate.

If it is damaged, the drive casing, together with the suspension, must be returned to the Manufacturer's Agent through the local agent.

Rear wheel drives with straight teeth (fitted to vehicles up to 1 907 980/908 000) are not being repaired at the Manufacturer's Agent but will be exchanged at a special price for those with bevel gears. The drive shaft (11 10 00 036) supplied must be used, as the shaft previously fitted is 0.118" (3 mm) longer and may cause trouble if it is fitted.

24. Refitting of rear wheel springing.

On the 125 cc engine, care must be taken to see that the gearwheel teeth are in relation to the bearing bush as shown in Fig. M 02/22 b, i. e. a gap between two teeth is in line with the bush.

Place paper washer on bearing bush (2 rubber gaskets on the 150 cc engine). Insert rear wheel springing or pullrod in the recess of the suspension. Oil bearing bush and drive in. Replace nut and washer and tighten.

Note. The bearing bush must not turn during tightening, otherwise the gasket will be damaged. Do not overtighten nut; the suspension must be able to move.

25. Refitting of rear brake

Oil brake shaft and replace with gasket and washer. Refit both brake shoes, with pull-off spring in position, and secure with spring ring. Replace bearing bush securing plate, refit brake lever (observe marking) and drive in position with a suitable piece of tubing, supporting the brake lever cam at the same time. Secure the brake lever with a circlip.

Brake lever must point to the top

Fit Woodruff key in drive shaft. Clean taper. Replace brake drum and secure with nut and spring washer. Retighten after the engine has been fitted into the chassis.



Fig. M 02/28

26. Refitting of gears

(not to be balanced)

Fit 24 needles with grease into the direct gear wheel and place into the outer ring of the drive casing. Insert driving shaft. Bring into correct position by turning the brake drum to and fro. Place the gear selector fork and inserted shaft on the complete countershaft and insert the complete assembly into the drive housing. Please note that the gear lever is slid into the recess of the gear selector fork. Place sliding gear of the main shaft (27 teeth) on to the gear selector fork and press towards the inside until it meshes with the direct gear wheel (= top gear). Oil all gears and stick paper gasket on the flange. Take the assembled gear casing out of the stand.

Secure gear change segment with bolt, spring washer and flat washer. Slide in pressure spring, screw in stud, and lock with nut.

29. Adjustment of gear change mechanism

The gear change mechanism is to be adjusted so that the distance from neutral to second gear is shorter than that from neutral to bottom gear. The roller of the operating lever when in bottom and top gear should be up against the surface and not the corner of the segment notch. Put into neutral and whilst turning the brake drum, move the gear casing slowly to the right until a clicking noise is heard (shortly before second gear is engaged). Move gear casing back slightly, until no noise can be heard. Tighten up countersunk screws, taking care that the position of the gear casing is not altered. Take engine from stand and refit.

27. Fitting of complete drive casing and suspension to the engine.

Place engine into stand. Place locating bolt into flange of gear casing and put into position on crankcase. Use locating bolt as guide. Press gear casing against the engine and, by moving the brake drum, engage the gear wheels. After the gears have been engaged, both housings can be joined **without using force**. Place flat washer, spring washer and nut on the locating bolt and tighten. Replace all socket head bolts and tighten with Allen key and special spanner. The long bolt fits on top of the flange housing (seat of gear casing). Press rear springing upwards and move suspension with a strong screwdriver until the holes in the housing and fixing bracket meet.

Grease nipple points to the right.

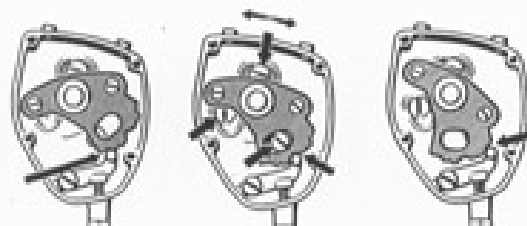

Bottom gear Second gear Top gear

Fig. M 02/28-29

28. Fitting of complete gearbox housing

Fit protecting washer. Place gearbox housing in position (slots in the housing must be in line with centre holes). Insert countersunk screws and cone shaped star washers, tighten lightly as gears have to be adjusted later. Make sure that top gear is engaged. Replace gear change segment. The notch for the top gear must point to operating lever.

Further work which may be carried out on the suspension:

30. Removal and refitting of cover with drive shaft for rear wheel suspension.

Unscrew brake shoe pivot. Take off all nuts. (There are no nuts on the 150 cc engine, but two socket head bolts). Loosen cover by tapping lightly with rubber mallet and take it off. Take off paper gasket and catch any grease which may come out.

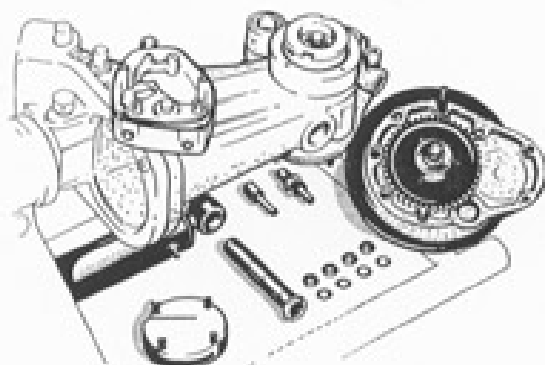

Fig. M 02/30

Refitting: Fill the recesses in the suspension with Epix or other pressure Lubrication grease.

replace gasket and cover, engage gears, and tighten cover.

31. Removal and refitting of drive shaft without shock absorber.

125 cc engine: Knock out carefully the dowel pin on the helical gear. Undo lock plate. Slacken nut with left-hand thread, thereby pulling off gear. Retighten nut slightly (to free the gear) and press off wheel with two strong screwdrivers.

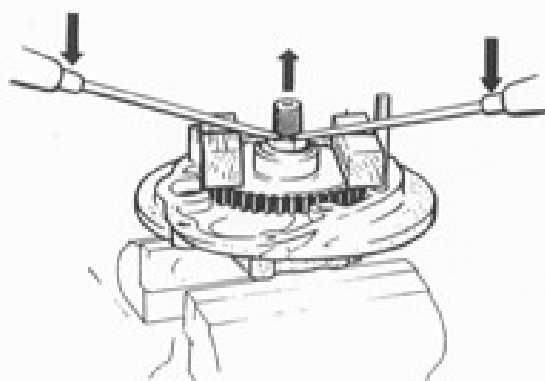

Fig. M 02/31

Take off the nut, shim and lock plate. Draw off ballrace and take off Woodruff key. Take off nuts and spring washer, remove flange cover. Insert mandrel, place in a vice or press, and press out the drive shaft together with dished springs and driving hub.

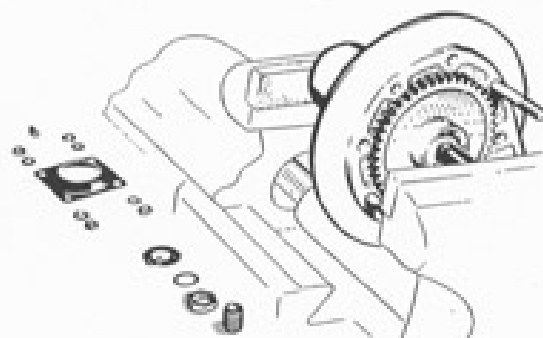

Fig. M 02/31a

Reassemble in reverse order.

31a Removal and refitting of drive shaft with shock absorber (Schnorr spring)

125 cc engine: After the dowel pin has been removed, take off the helical gear as described in para. 31. Take off grooved thrust washer and gearwheel. Take off three balls with driving plate. Remove flange cover. Insert mandrel, press out driving shaft together with dished springs, in a vice.



Fig. M 02/31 b

Refitting: Knock driving shaft together with ball race into cover, place covering disc in position, fit packing ring, and attach flange cover with spring washers and nuts. Insert dished springs as follows: dished spring (curved side down) covering disc, dished spring (curved side up), dished spring (curved side down), dished spring (curved side down) covering disc and final dished spring (curved side up). Place driving shaft carefully in a vice and make certain that the dished springs are seated correctly. Knock on driving hub with a piece of tubing.

The polished part of the hub points to the top.

Insert balls with grease and replace gear wheel. Replace grooved thrust washer, fit bearing, shim and lock plate. Tighten **left-hand threaded nut** and lock up. Press on helical gear. The shim must invariably be fitted, otherwise the lug of the lock plate will be sheared off. This in turn may cause the nut to come loose and do subsequent damage.

31b Removal and refitting of drive shaft with shock absorber (Schnorr spring).

150 cc engine: Removal instructions are the same as those for the 125 cc engine, described in para 31 a. When the hub has been taken off, the five dished springs, two wire rings and one thrust washer can be removed. Take off Woodruff key from the drive shaft and 4 nuts on the flange cover, and remove flange cover together with the pressed-in gasket. Push out driving shaft and flange with pressed-in bearing by tapping gently with a rubber mallet.

Refitting: Reassemble in reverse order.

When refitting the flange cover, it is important to remember that the guide bush (11 91 00 926) is placed on the gasket. Lock up left-hand threaded nut.

32. Removal and refitting of helical gear in the suspension.

Unscrew threaded pin with a suitable screwdriver and lever off helical gear with screwdriver. (Note shims).

Refit in reverse order, lock/securing screw with centre punch.

33. Dismantling and reassembly of rear wheel springing.

Support rear wheel springing in a vice, using wood jaws, and unscrew support bracket with a suitable spanner or bolt. Take out counter spring and shock absorber rubber. Tighten pull rod in a vice and unscrew pull rod base with special spanner (11 91 00 131). Remove inner and outer springs, as well as disc. Pull out pull rod, and clean and inspect all parts, exchange defective ones.

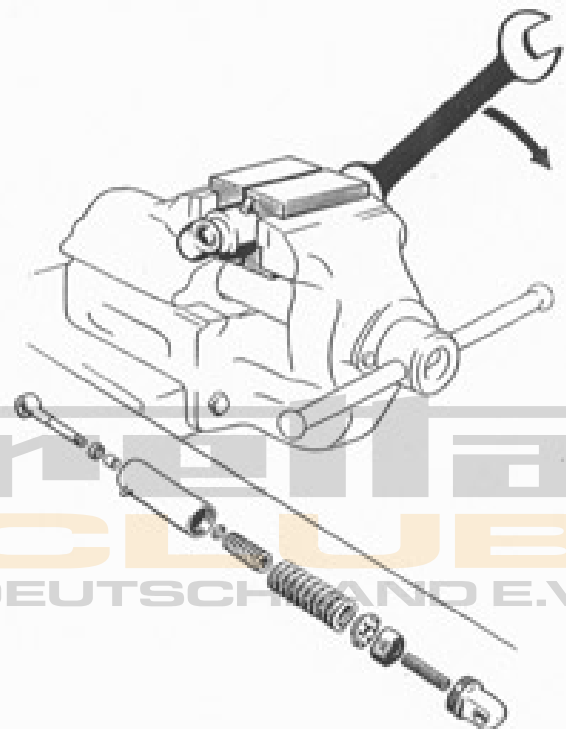

Fig. M 02/33

Reassemble in reverse order. Half fill rear-wheel springing with high pressure grease. Replace support bracket and lock with centre punch.

CARE AND MAINTENANCE

Lubrication (W 01)

1. Always follow lubrication chart and instruction book.

LUBRICATION CHART

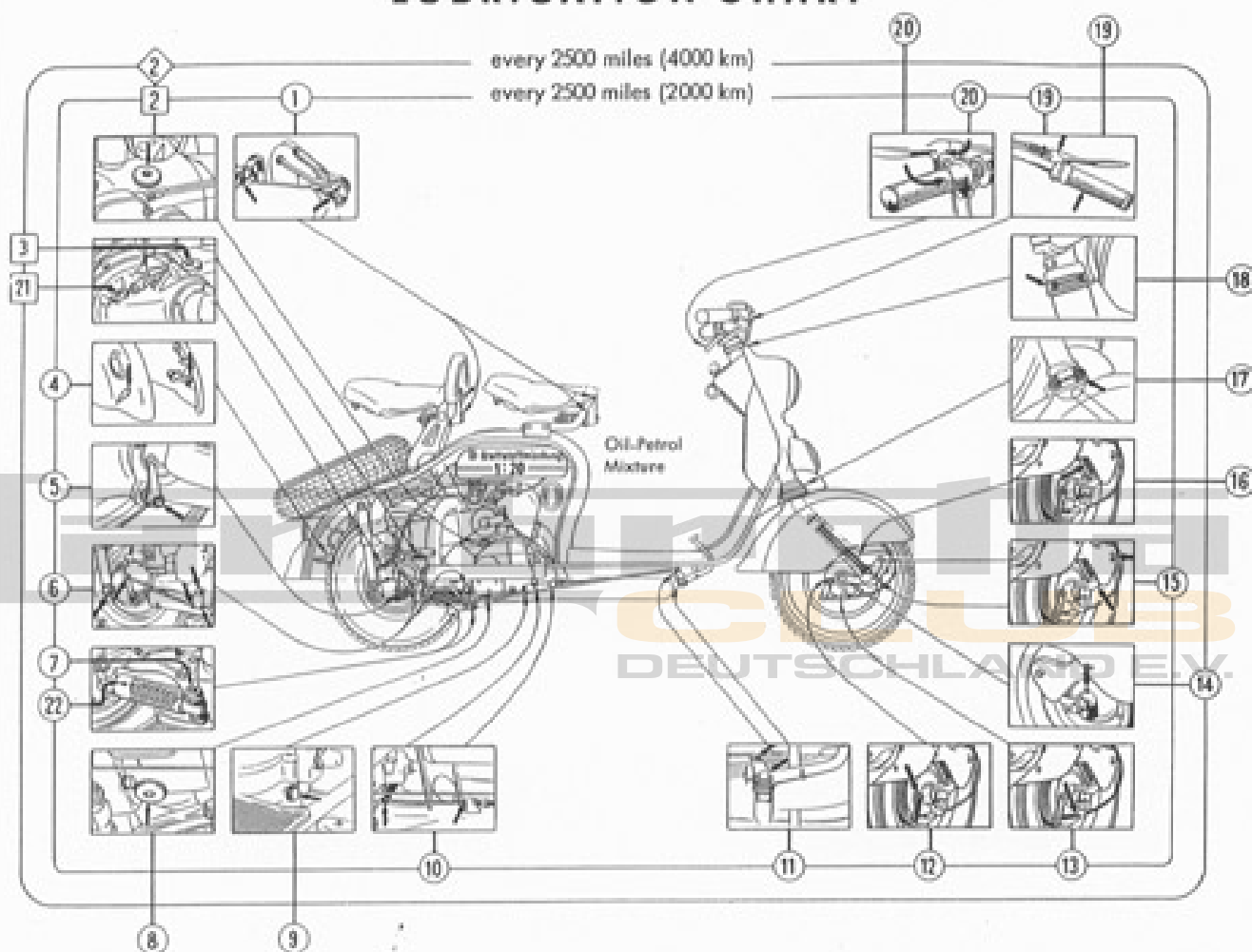

- | | |
|---|--|
| 1. Saddle pivot | 12. Front brake adjuster |
| 2. Oil filler plug, gearbox | 13. Front brake cable |
| 3. Grease filler plug, suspension bearing | 14. Front wheel hub |
| 4. Catches on side panelling | 15. Front suspension bearing and ball cup of front spring |
| 5. Rear-brake adjuster and rear mounting for rear wheel springing | 16. Front springs |
| 6. Rear-brake rod support, bell crank lever (intermediate lever) bearing, upper and lower joint of hydraulic shock absorber | 17. Lower steering joint |
| 7. Front mounting for rear-wheel springing | 18. Upper steering joint |
| 8. Gearbox drain plug | 19. Handbrake-cable joint (lubricate with oil), throttle twist grip (lubricate with grease) |
| 9. Gearbox oil level inspection plug | 20. Clutch lever joint (lubricate with oil), gear control twist grip (lubricate with grease) |
| 10. Clutch operating cable | 21. Grease filler plug, rear wheel bearing |
| 11. Foot brake pedal and brake rod support | 22. Rear wheel springing |

◇ — Oil change

□ — Topping-up

During bad weather, lubricate moving parts (front fork springing and brake levers, pivots of rear wheel springing, foot brake rods . . .) more frequently than stated.



<u>Lubrication point</u>	<u>Method of lubrication</u>	<u>Lubricant</u>
Lubrication pad on contact breaker	Every 6000 miles (10 000 km), pack pad with grease	High melting point grease (Melting point 302°-320°F)
Gearbox	After the first 300 miles (500 km), again after further 600 miles (1000 km) and afterwards regularly every 2500 miles (4000 km) drain off the oil while the engine is still warm. To do this, remove filler plug 2, drain plug 8, and level plug 9. Replace plug 8 and refill with oil until it starts to run out from the level plug (1/3 pint). (0.2 litres). Finally replace plugs 9 and 2.	Branded engine oil SAE 30 (or branded gear oil SAE 30)
2 8 9		
1, 4, 6, 11, 12, 19, 20	A few drops	
19 20	During overhauls or after 6000 miles, (10 000 km) remove throttle and gear change twist grips, grease inner parts	
5, 7, 22, 15	Lubricate with grease Grease 22 immediately if you hear any noise	
14	Apply a little grease	High pressure grease
10 13	Grease control cables at points of attachment and where they enter the outer casings at top bottom.	
16	During overhauls, grease springs before assembly	
17 18	Clean and repack balls with grease during overhauls or after appr. 6000 miles (10 000 km)	
3	Pack up to the level of the filler plug	
21	After 2500 miles (4000 km), fill with 2 oz. (50 gr.) grease. After further 2500 miles (4000 km), take off rear suspension cover and remove all grease. Refill with 5 oz. (140 gr.) grease, but no more. Topping up and renewal to alternate every 2500 miles (4000 km).	Grease such as Retinax 6 or Mobil Epix

Lambretta
CLUB
DEUTSCHLAND E.V.



SERVICE

Special tools for NSU-PRIMA

For Servicing and repair work with engine in situ.

NSU-PRIMA 150 cc
Special tools / Page 1
Edition XII, 1955

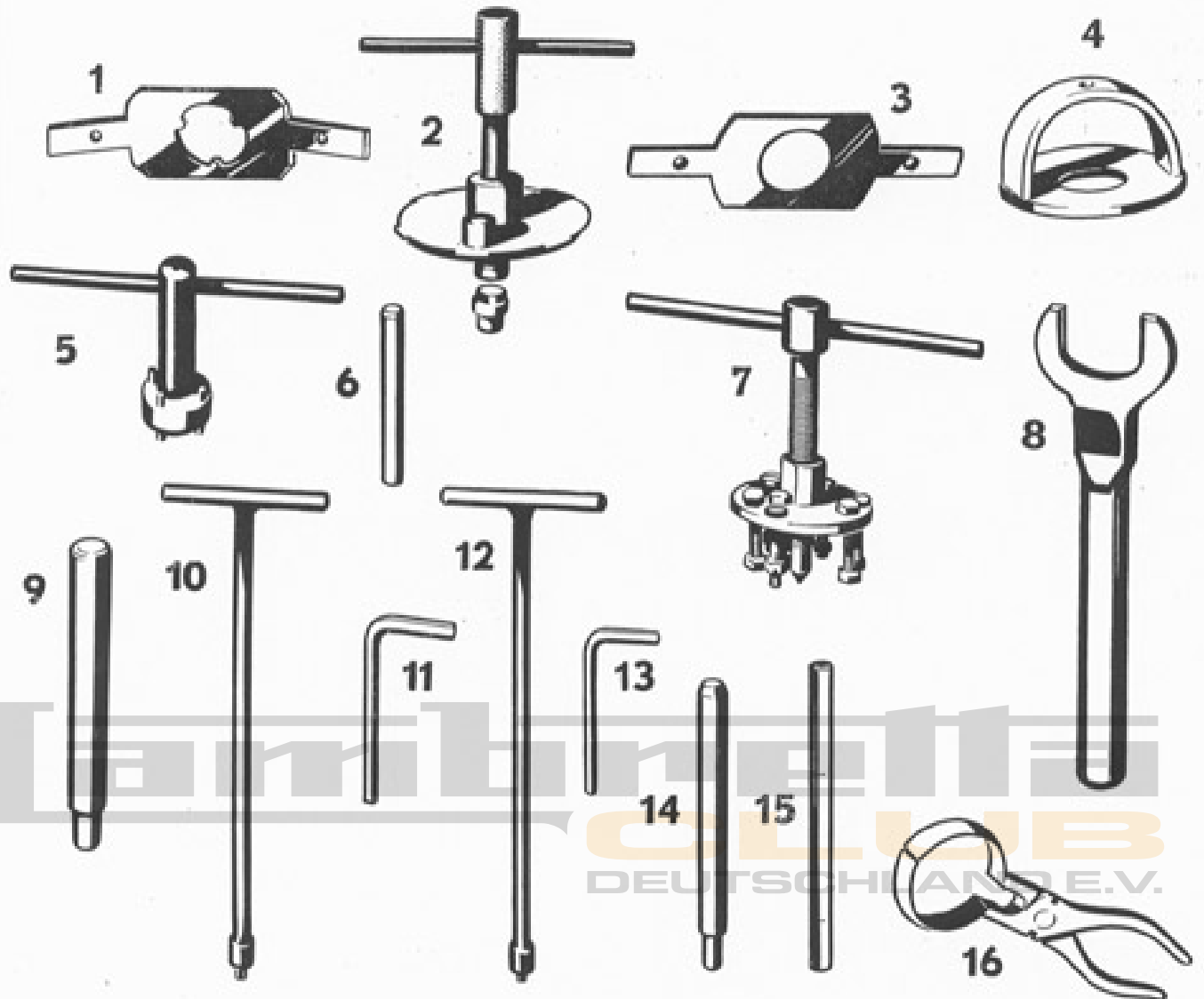
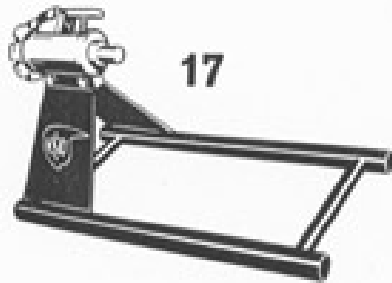
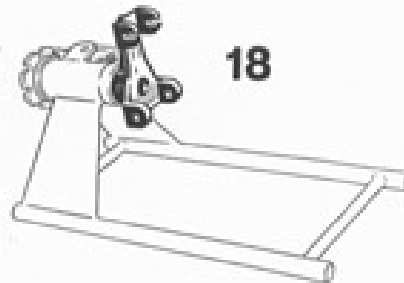

Fig. 1	1 support for clutch hub	11 91 01 108
Fig. 2	1 clutchbell drawer	11 91 01 123
Fig. 3	1 support for clutchbell	11 91 00 130
Fig. 4	1 clutch jig	11 91 02 134
Fig. 5	1 special tool for rear wheel springing	11 91 00 131
Fig. 6	1 punch for removing brake adjuster	11 91 00 921
Fig. 7	1 drawer for brake drum	018 099 743
Fig. 8	1 spanner for upper bearing ring	11 91 00 128
Fig. 9	1 punch for fitting distance- and bearing bush	11 91 00 920
Fig. 10	1 socket spanner 5 mm (0.197") for housing screws	11 91 00 111
Fig. 11	1 Allen key 5 mm (0.197") for housing screws	11 91 00 604
Fig. 12	1 socket spanner 6 mm (0.236") for housing screws	11 91 00 124
Fig. 13	1 Allen key 6 mm (0.236") for housing screws	11 91 00 603
Fig. 14	1 mandrel for gudgeon pin	11 91 00 919
Fig. 15	1 punch for checking connecting rod	048 422 014
Fig. 16	1 piston ring compressor	11 91 01 922



17



18

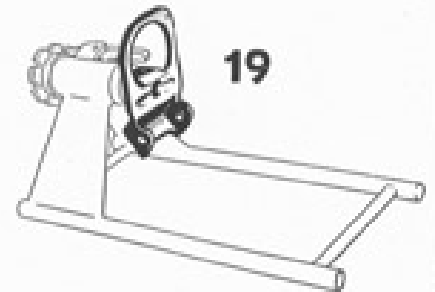

19



20

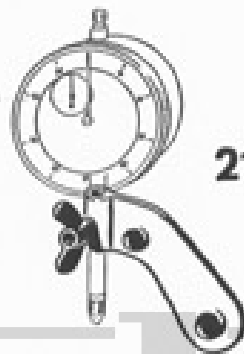

21

Lambretta
CLUB
DEUTSCHLAND E.V.

Fig. 17	1 stand	048 422 000
Fig. 18	1 fixture for holding engine	11 91 01 917
Fig. 19	1 fixture for rear wheel drive	11 91 00 916
Fig. 20	1 punch for removing (split) clutch ballrace	11 91 00 924
Fig. 21	1 bracket for dial gauge	11 91 00 912

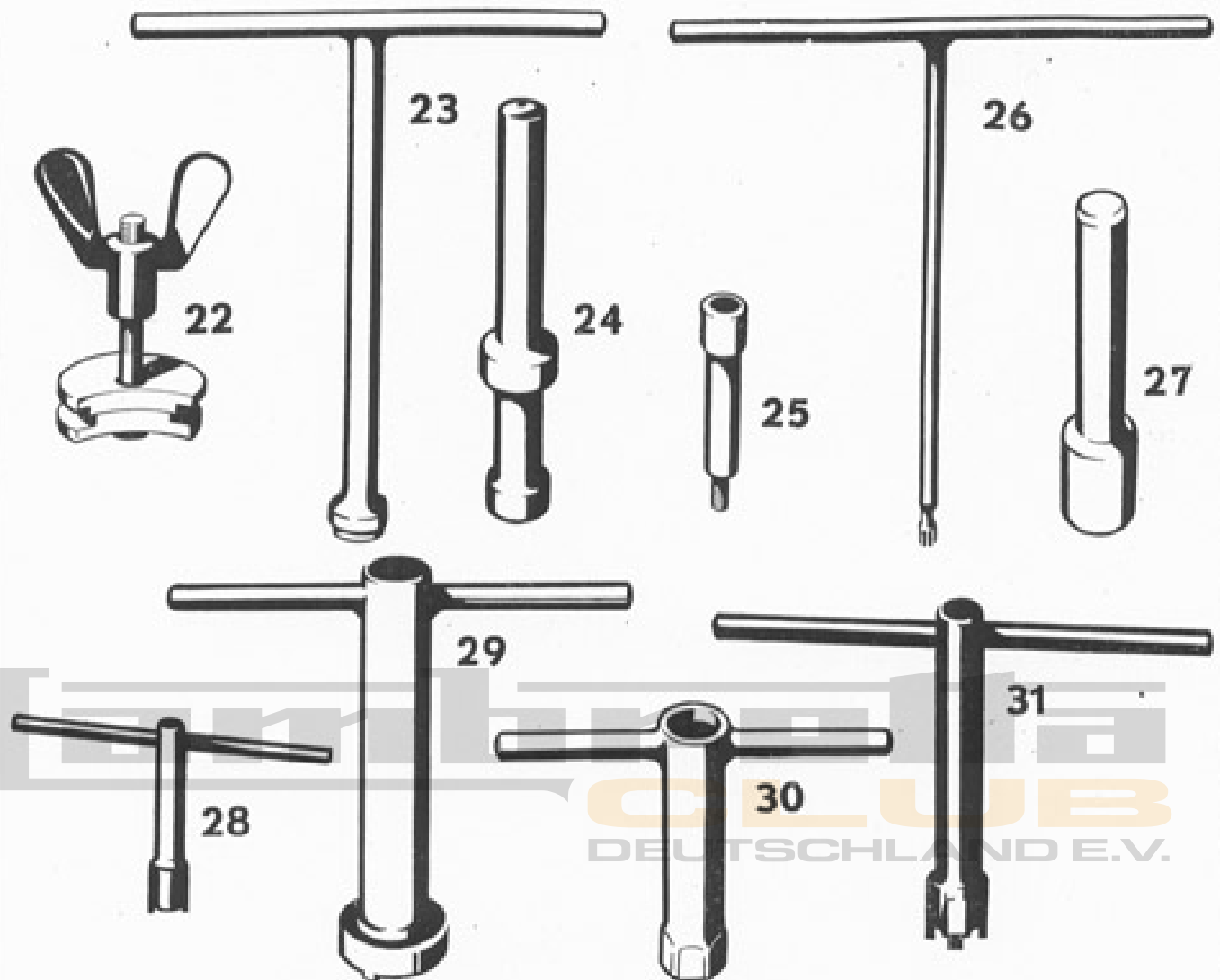

Fig. 22	1 suspension fitting tool	11 91 00 122
Fig. 23	1 socket spanner for magneto flywheel nut	11 91 00 110
Fig. 24	1 punch for knocking in ball bearing (bevel pinion)	11 91 00 908
Fig. 25	1 drawer for bevel pinion	11 91 00 129
Fig. 26	1 holding tool for bevel pinion	11 91 00 903
Fig. 27	1 punch for fitting bevel pinion gasket	11 91 00 918
Fig. 28	1 spanner	11 91 00 133
Fig. 29	1 socket spanner for outer suspension screwed joint	078 791 905
Fig. 30	1 box spanner 24 mm (15/16") for bevel pinion nut	11 91 00 904
Fig. 31	1 spanner for inner screws	11 91 00 909



SERVICE

FLAT RATE TIMES FOR REPAIR TASKS

NSU-PRIMA 150 cc
Standard times / Page 1
Edition XII. 1955

The standard times are calculated for vehicles with standard equipment; additional time required for cleaning is not included.

Engine

M 01	Remove and refit engine (including test run on stand)
M 02	Dismantle and reassemble engine (including adjustment)
M 03	Remove and refit rear wheel drive with suspension
M 04	Remove and refit cylinder head
M 10	Remove and refit cylinder block and piston
M 11	Decarbonising of cylinder head and exhaust system (without removal of cylinder block)
	As above (with removal of cylinder block)
M 12	Remove and refit gudgeon pin (including reaming)
M 15	Remove and refit clutch
M 26	Centralise crankshaft (125 cc only)

M 27	Remove and refit bearing cover
M 30	Exchange crankshaft and bearing, including lining-up bevel gears
M 35	Remove and refit gears and gear change mechanism
M 36	Remove and refit gear shaft bearing and bushes
M 37	Adjust gear change
M 51	Remove and refit airducts (left and right hand)
M 52	Cover for rear wheel suspension

Ignition and generator

Z 01	Set ignition timing
Z 02	Remove and refit generator and adjust
Z 03	Remove and refit contact breaker points and adjust
Z 04	Remove and refit condenser and test
Z 05	Remove and refit ignition coil
Z 06	Remove and refit ignition high tension cable
Z 07	Remove and refit control box
Z 08	Remove and refit carbon brushes

Carburettor

V 01	Remove and refit air filter and clean
V 02	Remove and refit carburettor, clean and adjust

Job time: (hours)	Additional work necessary	Total time: (hours)
Temps élémentaires (heures)	Opérations annexes nécessaires	Temps total (heures)
Gedetail- eerde richtijd (uur)	Vereiste bijkomstige werkzaamheden	Total- tijd (uur)
	M 51, F 02, F 62, F 70, F 76, F 91	3½
6	M 01, M 03	11
2	F 02, F 91	2½
¼	M 51, F 76, F 80	1
½	M 51, F 76, F 80, M 04	1½
¼	M 04, M 51, F 70, F 76, F 80	1¾
¾	M 04, M 51, F 70, F 76, F 80	2¼
½	M 04, M 10, M 51 F 76, F 80	2
1½	F 91	1¾
1½	M 04, M 27, M 51, Z 02, F 76, F 80 F 91	4
¾	M 51, Z 02, F 91,	1¾
1	M 01, M 02, M 03	12½
1	M 03, M 15	4½
¼	M 01, M 02, M 03	11¾
½	Road test	1
¼	—	¼
1	F 02, F 05	1½
¾	—	¾
½	M 51, F 91	1
1¼	—	1¼
1¼	—	1¼
1	(possibly Z 02)	(1½)
¾	(possibly Z 02)	(1¼)
1	M 51	1¼
	M 51, F 91	½
¾	with noise suppressor	½
¾	V 01 or V 01 with noise suppressor	½ ¾

Wheels, brake hubs and fork

F 01	Remove and refit front wheel
F 02	Remove and refit rear wheel
F 03	Remove and refit hub ballrace and sealing ring
F 04	Remove and refit front wheel brake disc
F 05	Remove and refit rear wheel hub
F 08	Renew brake linings (per wheel) dismantling and reassembly of brake
F 09	Remove and refit speedometer drive
F 20	Remove and refit front fork
F 21	Remove and refit bearing bushes, bearings and balls
F 22	Remove and refit front fork springs
F 24	Remove and refit suspension arm (left and right)
F 25	Rebush suspension arm
F 26	Remove and refit front wing
F 30	Remove and refit fork cowling

Controls and levers

F 40	Remove and refit handlebar (with instruments)
F 41	Remove and refit handlebar
F 42	Remove and refit speedometer
F 43	Remove and refit speedometer drive
F 44	Remove and refit handle bar lever
F 45	Remove and refit throttle twist grip
F 46	Remove and refit gear change twist grip
F 47	Remove and refit twist grip cover
F 50	Remove and refit clutch operating cable
F 51	Remove and refit brake cable
F 53	Remove and refit throttle cable
F 54	Remove and refit gear change cable
F 55	Remove and refit choke control

Frame

F 60	Remove and refit frame
F 61	Remove and refit centre piece
F 62	Remove and refit rear wheel wing
F 65	Remove and refit rear wheel shock absorber

Job time: (hours)	Additional work necessary	Total time: (hours)
Temps élémentaires (heures)	Opérations annexes nécessaires	Temps total (heures)
Gedetail- erde richtijd (uur)	Vereiste bijkomstige werkzaamheden	Totaal- tijd (uur)
¼	—	¼
¼	—	¼
¼	F 01, F 04	¾
¼	F 01	½
¼	F 02	½
½	F 01, F 04 or F 02, F 05	1 1
½	M 52, F 02, F 05	2
¾	F 01	1
½	F 01, F 20	1½
¼	F 01, F 24 or F 01, F 20, F 24, F 26, F 46	¾ 2¼
¼	F 01	½
¾	F 01, F 24	1¼
¼	F 01, F 20	1¼
—	E 06, E 13	½
¾	—	¾
¾	F 44, F 45, E 10	1
¾	—	¾
¾	F 30	¾
¾	—	¾
¾	—	¾
½	—	½
¾	—	¾
½	E 13	¾
½	E 13	¾
¾	F 45, E 13	¾
1	F 46, E 13	1¾
½	E 13	¾
—	M 01, F 01, F 20, F 21, F 46, F 50 F 51, F 55, F 61, F 72, F 90, E 13	12½
¾	F 02, F 71, F 72, F 76, F 80, E 09	2½
¾	F 02	¾
¾	—	¾



SERVICE

FLAT RATE TIMES FOR REPAIR TASKS

NSU-PRIMA 150 cc
Standard times / Page 3
Edition XII, 1955

F 67	Remove and refit rear wheel springing
F 68	Remove and refit fixing bolt and bush
F 70	Remove and refit exhaust system
F 71	Remove and refit pillion seat
F 72	Remove and refit rider's seat
F 73	Remove and refit prop stand
F 74	Remove and refit centre stand (with pull-off spring)
F 76	Remove and refit tool box
F 80	Remove and refit fuel tank
F 82	Remove and refit fuel tap
F 90	Remove and refit leg shield
F 91	Remove and refit foot rest

Job time: (hours)	Additional work necessary	Total time: (hours)		
Temps élémentaires (heures)	Opérations annexes nécessaires	Temps total (heures)		
Gedetaille- erde richtijd (uur)	Vereiste bijkomstige werkzaamheden	Totaal- tijd (uur)		
3/4	F 02, F 05	1 1/4		
3/4	F 02, F 05, F 67	1 1/2		
1/2	—	1/2		
3/4	—	3/4		
3/4	—	3/4		
3/4	—	3/4		
1/2	—	1/2		
3/4	—	3/4		
3/4	—	3/4		
3/4	—	3/4		
1 1/4	F 30, E 15, E 14, E 19	2 1/2		
3/4	—	3/4		
Electric installation				
E 01	Horn cable	} Remove and refit cable harness		
E 02	Tail lamp cable			
E 03	Battery cable			
E 04	Headlamp cable			
E 05	Remove and refit dipper cable	3/4	E 10, E 13	3/4
E 06	Remove and refit horn	3/4	F 30	3/4
E 09	Remove and refit tail lamp	3/4	—	3/4
E 10	Remove and refit dipper switch	3/4	—	3/4
E 12	Remove and refit headlamp reflector and glass . .	3/4	E 13	1 1/2
E 13	Remove and refit headlamp	3/4	—	3/4
E 15	Remove and refit one battery	3/4	—	3/4
E 16	Remove and refit battery box	3/4	E 15	1 1/2
E 17	Remove and refit clock	3/4	—	3/4
E 18	Remove and refit ignition switch	1/2	—	1/2
E 19	Remove and refit instrument panel	3/4	F 30, E 15, E 16, E 17, E 18, F 42	1 3/4

